

WATERCO POOL HEAT PUMP

Electr  Heat
Pro 60kW

Installation and Operation Manual



OFFICES - AUSTRALIA

NSW - SYDNEY
(HEAD OFFICE)
TEL: +61 2 9898 8600

QLD - BRISBANE
TEL: +61 7 3299 9900

VIC/TAS - MELBOURNE
TEL: +61 3 9764 1211

WA - PERTH
TEL: +61 8 9273 1900

SA/NT - ADELAIDE
TEL: +61 8 8244 6000

ACT DISTRIBUTION
TEL: +61 2 6280 6476

OFFICES - OVERSEAS

WATERCO (EUROPE) LIMITED
SITTINGBOURNE, KENT. UK
TEL: +44 (0) 1795 521 733

WATERCO (USA) INC
AUGUSTA, GEORGIA, USA
TEL: +1 706 793 7291

WATERCO CANADA
BOUCHERVILLE, QUEBEC,
CANADA
TEL: +1 450 748 1421

WATERCO (NZ) LIMITED
AUCKLAND, NEW ZEALAND
TEL: +64 9 525 7570

WATERCO (C) LIMITED
GUANGZHOU, CHINA
TEL: +86 20 3222 2180

WATERCO (FAR EAST) SDN BHD
SELANGOR, MALAYSIA
TEL: +60 3 6145 6000

PT WATERCO INDONESIA
JAKARTA, INDONESIA
TEL: +62 21 4585 1481

WATERCO INTERNATIONAL PTE LTD
MIDVIEW CITY, SINGAPORE
PH: +65 6344 2378

WATERCO VIETNAM COMPANY LIMITED
HO CHI MINH CITY, VIETNAM
TEL: +84 28 3622 7780

WARNING

This equipment must be installed and serviced by a qualified technician. Improper installation can create electrical hazards which could result in property damage, serious injury or death. Improper installation will void the warranty.



Notice to Installer

This manual contains important information about the installation, operation and safe use of this product. Once the product has been installed this manual must be given to the owner/operator of this equipment.

WATERCO

Waterco Limited ABN 62 002 070 733



WATERCO

water, the liquid of life

www.waterco.com

Table of Contents

IMPORTANT SAFETY INSTRUCTIONS -----	02	MAINTENANCE OF YOUR POOL HEAT PUMP ----	31
A NOTE TO YOU -----	03	Cabinet Cleaning -----	31
INSTALLATION INSTRUCTIONS -----	05	Cleaning Evaporator -----	31
Location -----	05	Cleaning drainage holes -----	31
Locating The Installation Accessories -----	05	Units Located In Coastal Locations -----	31
Installation -----	07	Winterising Procedure -----	32
Water Piping -----	08	GENERAL SAFETY INSTRUCTIONS -----	33
Plumbing Diagram -----	09	TROUBLESHOOTING -----	34
Electrical -----	10	Nothing Is Working and The Electronic	
Electrical Connection -----	10	Control Does Not Operate -----	34
Breaker Size -----	10	Nothing Is Working But The Electronic Control	
Electrical Wire Size -----	10	Temperature Displays Digits or a Code -----	34
How to connect to the terminal board -----	11	Fan Doesn't Work (The Fan Blades	
Electrical Wiring Diagram -----	12	Are Not Moving) -----	34
References for protecting devices and cable		Fan Blades Turn, But Compressor Is Not	
specification -----	12	Functioning -----	35
Bonding -----	13	Compressor Starts and Stops -----	35
Remote Control Connections-----	13	There Is Water Around The Pool Heat Pump ---	35
Operating Range -----	14	Pool Heat Pump Has Ice Formed On The	
Introduction of Different Modes -----	14	Evaporator Coil -----	36
Performance Specifications -----	17	Pool Heat Pump Is Functioning, But Does Not	
Wi-Fi OPERATION		Reach The Desired Temperature Setting -----	36
InverGo Download -----	18	Circuit Breaker Trips -----	37
Account Registration -----	18	The Pool Heat Pump Is Noisy -----	37
Create Family -----	19	The Temperature Shown On Pool Heat Pump	
APP Pairing -----	20	Is Not The Same That Is Shown By The Pool	
Operation -----	22	Thermometer -----	37
Share Devices to Your Family Members -----	23	Dimension -----	38
OPERATION OF YOUR POOL HEAT PUMP		Failure solution and code -----	39
Initial Heating -----	24	Protection & Failure code -----	40
Adjustment Of The Bypass Valves -----	24	WARRANTY -----	41
Pool Heat Pump Running Time -----	25		
Operation Guide -----	26		
Screen Display-----	27		
Operation Instruction -----	28		

IMPORTANT SAFETY INSTRUCTIONS

When using this electrical equipment, basic safety precautions should always be followed, including the following:

READ AND FOLLOW ALL INSTRUCTIONS

! WARNING: Disconnect all AC power during installation and servicing.

! WARNING: In order to avoid the possibility of hyperthermia (heat stress) occurring it is recommended the average temperature of the spa - pool water does not exceed 40°C / 104°F.

! WARNING: The pool heat pump is not intended for use by persons (including children) with reduced physical sensory or mental capabilities, or lack of experience and knowledge, unless they have been provided supervision or instruction concerning use of the appliance by a person responsible for their safety. Children should be supervised to ensure they do not play with the appliance.

- In certain situations unexpected start up may occur when the appliance is in automatic mode.
- The installer should assess the risk associated with unexpected start-up of this device which, in any circumstance should have no hazardous effect.
- The pool heat pump is not meant to provide safety protection for other devices.
- The pool heat pump should be deactivated if the pool or spa has been drained.
- Waterco pool heat pumps must be installed by a suitably qualified person in accordance with current Regulatory Standards, the applicable Wiring Rules (AS3000) and local statutory authority regulations.
- Parts containing live parts, except parts supplied with safety extra-low voltage not exceeding 12V, must be inaccessible to a person in the spa - pool.
- Parts incorporating electrical components, except remote control devices, must be located or fixed so that they cannot fall into the spa - pool.
- The appliance should be supplied through a residual current device (RCD) having a rated residual operating current not exceeding 30mA.
- An Earth terminal is located inside the wiring enclosure. To reduce the risk of electric shock, this terminal must be connected to the grounding means provided in the electric supply service panel with a continuous copper wire as sized to comply with current Standards and local statutory authorities in relation to the circuit conductors supplying the equipment.
- A cable connector is provided on this unit to connect a suitably sized copper conductor between this unit and any metal equipment, metal enclosures of electrical equipment, metal water pipe, or conduit within 1.5m of the unit via equipotential bonding.

SAVE THESE INSTRUCTIONS.

A NOTE TO YOU

Congratulations!

Thank you for choosing a Waterco Electroheat PRO 60 inverter heat pump to heat your pool.

Using the latest technology in heat capture, the Waterco pool heat pump converts the energy released by the sun and transfers it efficiently to your swimming pool.

During certain periods it may be necessary to operate your pool heat pump continuously during the day in cooler periods however, this should not be of concern as your Waterco pool heat pump can heat up your pool approximately 80% more economically than the fossil fuel heating or heaters with electric elements. Waterco pool heat pumps are designed specifically to heat or cool your swimming pool economically.

To appreciate the benefits this product will bring you, make sure to operate the unit when the atmospheric conditions specified in this document are present in addition of using a solar blanket to minimize heat loss which will influence operating costs and size of the unit required. Pools not covered with a solar blanket lose 2 to 3 times more heat, regardless of types of heating!

This manual applied to the following models:

Electroheat PRO 60 - heat / cool with automatic evaporator deicing

Transportation and Storage

1. The heat pump MUST be transported and stored VERTICALLY!



Do not lift the water union as you may damage the heat exchanger

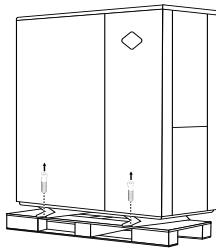

The heat pump is supplied mounted to a pallet. Once transported to site, remove the screws securing the pallet to the unit to install on the prepared slab / brackets.



Record your model's information.

Keep this manual and your original proof of purchase receipt for warranty and future reference.

On the base of your pool heat pump is a name plate which contains information such as model number, serial number and electrical information.

Please write these down below and have them handy incase of a service call request.

Model Number _____

Serial Number _____

Purchase Date _____

Dealer Name _____

Dealer Address _____

Dealer Phone _____

To find detailed product information, the location of the nearest dealer or to register your pool heat pump please visit our website www.waterco.com and select your location.

INSTALLATION INSTRUCTIONS

Location

To gain maximum efficiency for your pool heat pump please follow all instructions when "positioning the unit". It is also important to allow clearances for future service and maintenance procedures.

The unit is designed for outdoor installation and should not be installed in a totally enclosed area such as a shed, garage, etc., unless ducted and fan assisted ventilation of the cold exhaust air is provided to ensure adequate air exchange for correct operation.

The unit should be located as close as practically possible to the existing pool pump and filter to minimize water piping. The use of 90 degree bends and short radius elbows in the water piping should be kept to a minimum.

Mount the unit on a sturdy base, preferably a concrete slab. The base should be completely isolated from the building foundation or wall to prevent the possibility of sound or vibration transmission into the building. The size of the base should not be less than the base mounting feet dimensions of the pool heat pump.

LOCATING THE INSTALLATION ACCESSORIES

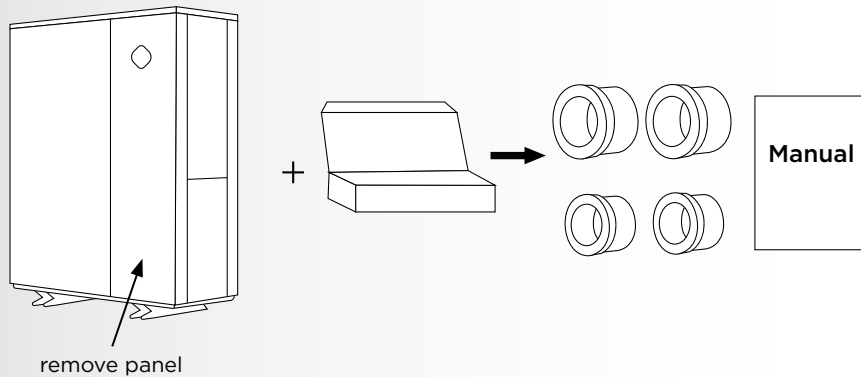

Installation Clearances

Air is pulled through the evaporator coil at the rear of the unit and discharged from the two front fan grills. Clearances must be allowed in front and around the unit for unrestricted air discharge and service access. See Figure 1. Failure to comply to the set clearances may cause diminished unit performance and reduce unit longevity.

The unit shall be sited in a well ventilated area in order to avoid trapped cold discharge air. Re-circulation of cold discharged air back into the evaporator coil should be avoided and will greatly reduce unit's heating capacity and efficiency.

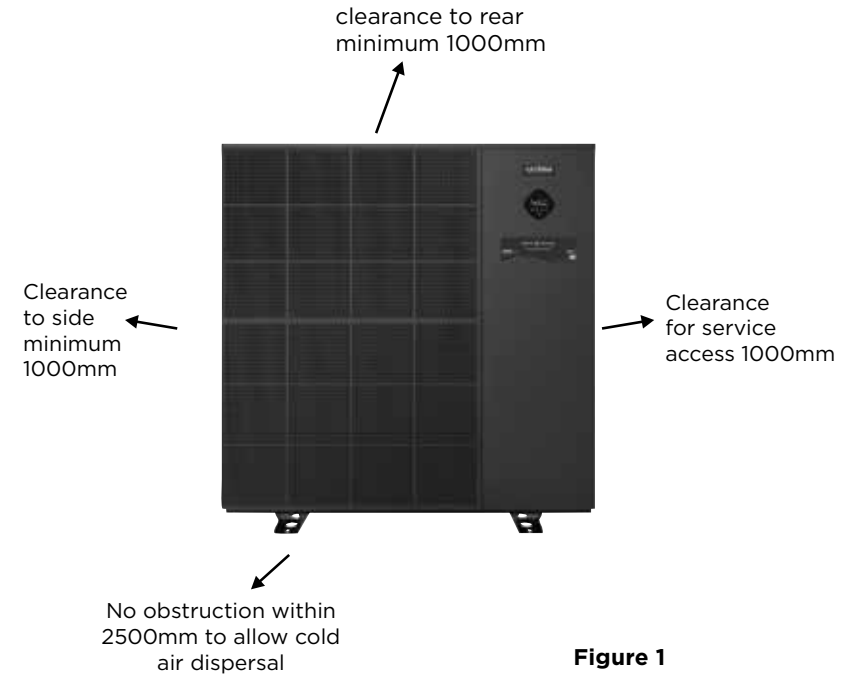

Installation

1. The frame must be fixed by bolts (M10) to concrete foundation or brackets (as shown in picture). The concrete foundation must be solid and fastened; the bracket must be strong enough and antirust treated;

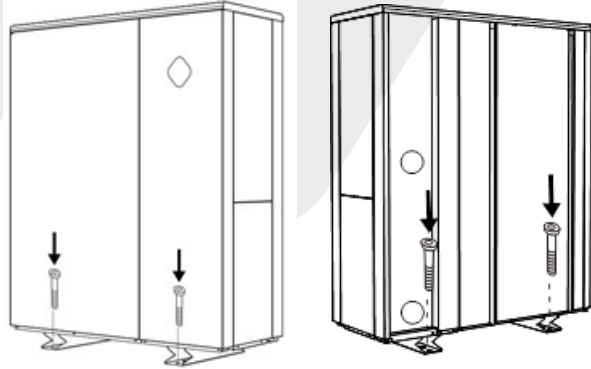

2. Please don't stack substances that will block air flow near inlet or outlet area, and there is no barrier behind the machine, or it will affect the efficiency of the heat pump and even stop the machine;
3. When the machine is running, there will be condensation water discharged from the drain pipe on the underside of the unit. Please connect a pipe with 1 inch diameter to drainage hole to drain the condensation water away from the unit.

Water Piping

The supplied plumbing layout must be followed without exception:

1. pool pump
2. filter
3. pool heat pump
4. chlorinator (when installed).

Rigid PVC piping is recommended with all joints primed and glued with a suitable PVC adhesive cement. If rigid PVC pipe is not available, a suitable flexible hose of adequate diameter may be utilised with stainless steel clamps. When the piping installation is complete, operate the pool pump and check the system for leaks. Then check the filter pressure gauge to see that excessive pump head pressure is not indicated.

Water Flow Rate

The recommended water flow rate range varies depending on the size of the heat pump to ensure maximum heat transfer efficiency. The optimal flow rate is the mid point of this range. Use the bypass valve to adjust the flow rate to within the recommended range. See Performance Specifications table page 15. The water temperature rise through the unit ideally should be between 2 - 3 degrees C which will vary dependent on the ambient air temperature.

Water By-pass Kit

A bypass kit consisting of 3 X two way valves must be installed for adjustment of water flow and ease of service. Waterco offer prefabricated water bypass kits to fit their heat pump domestic range. Ask your local Waterco sales office for details.



Plumbing Diagram

⚠ VITAL

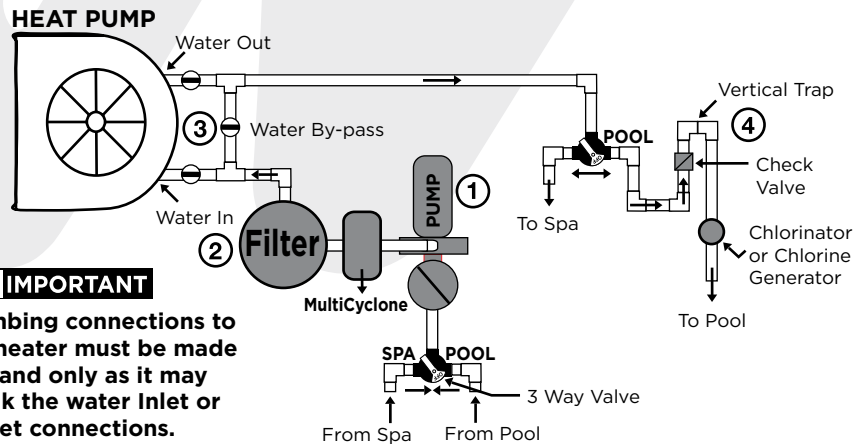

⚠ IMPORTANT

Plumbing connections to the heater must be made by hand only as it may break the water Inlet or Outlet connections.

1. A check valve or a loop **MUST** be installed between the pool heat pump and any automatic chlorinator to prevent highly chlorine concentrated water from flowing back to the pool heat pump when the pool pump is not running.
2. These units are fitted with a flow switch which are not effected by water pressure. Therefore, the fitment of a flow check valve due to the installed height either above or below water level is not required.
3. For units installed above the pool water level the return water to the pool valve on the bypass valve set should be closed approximately 15-20% to ensure the heat exchanger is completely full of water to allow heat transfer to occur.

⚠ IMPORTANT

Electrical

All electrical work should be performed by a fully qualified and licensed electrician in accordance with local electrical codes.

An adequate circuit breaker and copper wiring must be used. Electrical requirements are available on the name plate of the pool heat pump. It may be necessary to install an earth leakage circuit breaker.

Waterco recommend connecting the unit to an isolating switch to allow ease of service and maintenance.

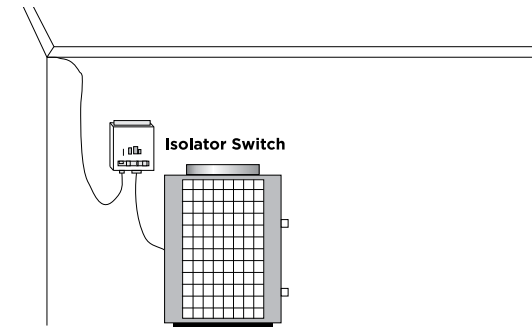

⚠ WARNING THE POOL HEAT PUMP MUST BE DISCONNECTED BEFORE OPENING THE ACCESS PANEL.

Electrical Connection

Standard 60 Hz power supply : 400 / 415V - 3 phase

Standard 50 Hz power supply : 400 / 415V - 3 phase

Breaker Size

Please consult name plate on the base or the side of your pool heat pump for starting amperage and required breaker size.

Electrical Wire Size

Please consult a qualified and licensed electrician.

⚠ WARNING The power cable ground must be connected to the electrical panel and to the ground lug of the pool heat pump. An improper installation may be a potential cause of fire, electrical shock or injury.

How to connect to the terminal board

1 Remove the screws



2 Disassemble the right down panel and terminal board cover

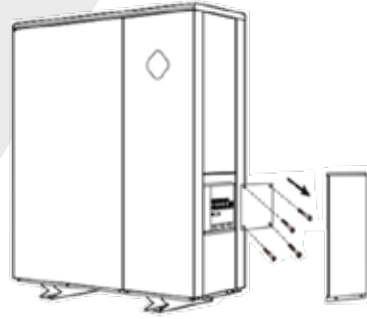

3 Connect the wire

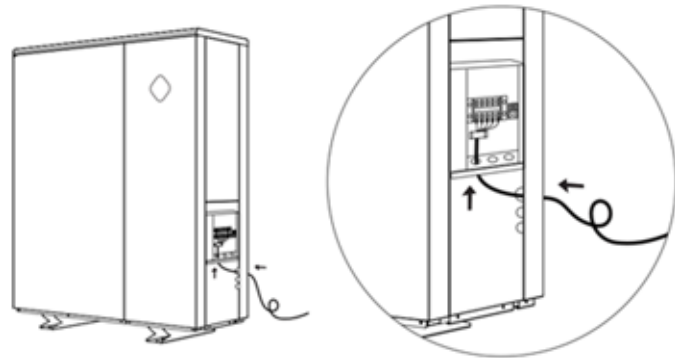

4 Restore the terminal board cover and right down pane

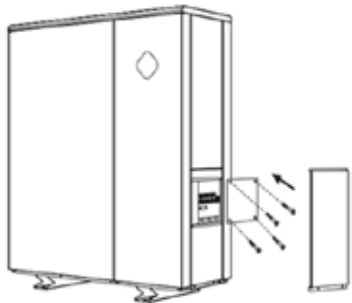

5 Fix the screws



Electrical Wiring Diagram

For power supply: 400V 50Hz

References for protecting devices and cable specification

	MODEL	IMC60WAT
Breaker	Rated Current (A)	25
	Rated Residual Current Device (mA)	30
Fuse (A)		25
Power Cord (mm ²)		5x4
Signal Cable (mm ²)		3x0.5
Maximum Current (A)		19

*Above data is subject to modification without notice.

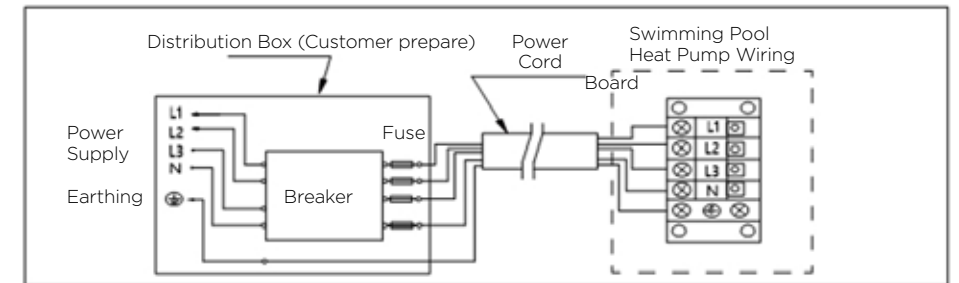

Bonding Diagram

⚠ VITAL

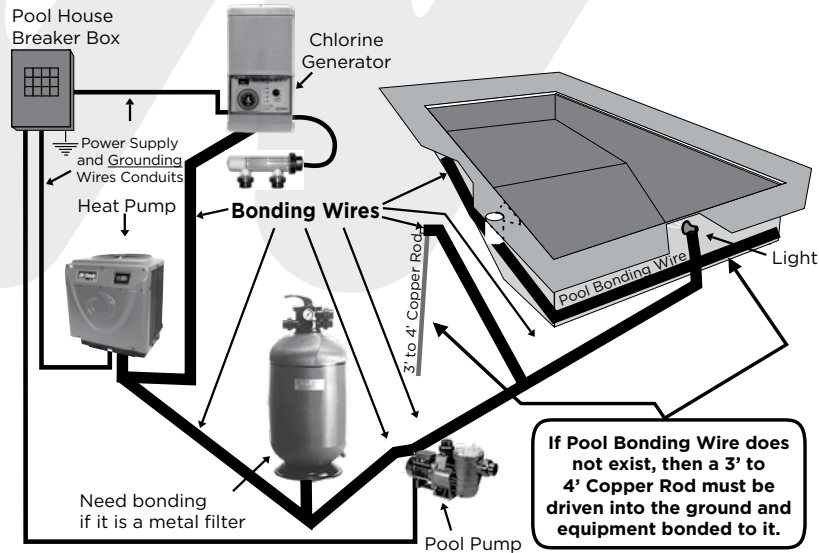

Remote Control Connections

1. Switch off power to heat pump at main circuit breaker panel/isolator.
2. Unbolt and remove the access panel. On the side of the unit.
3. Locate terminals marked 5 & 6. Take the two wires from the external automation system heater contact and connect. One wire into terminal 5 and one wire into terminal 6.
4. Via the terminals P1 & P2, the heat pump may control a contactor which can switch a pump to provide water flow to the unit. The the water pump should be supplied with it's own power circuit and be wired as per the wiring diagram opposite.

Operating Range

To provide you comfort and pleasure, please set swimming pool water temperature efficiently and economically.

- a. The heat pump can work between air -20°C - 43°C,
- b. Temperature of heating 18°C - 40°C
- c. Temperature of cooling 12°C - 30°C

Ideal operation range is between air 15°C - 25°C.

Introduction of Different Modes

- a. The heat pump has three modes: Turbo, Perfect and Silence.
- b. They have different strengths under different conditions.

MODE	MODES	Strength
	Turbo mode	Heating capacity: 100% - 20% capacity Fast heating
	Perfect mode	Heating capacity: 80% - 20% capacity Automatic adjustment according to ambient and water temperature, intelligent optimization. High efficiency and energy saving
	Silence mode	Heating capacity: 50% - 20% capacity Operating at night.

Electrical wiring schematic

Water Pump: 400V Voltage

Please install contactor

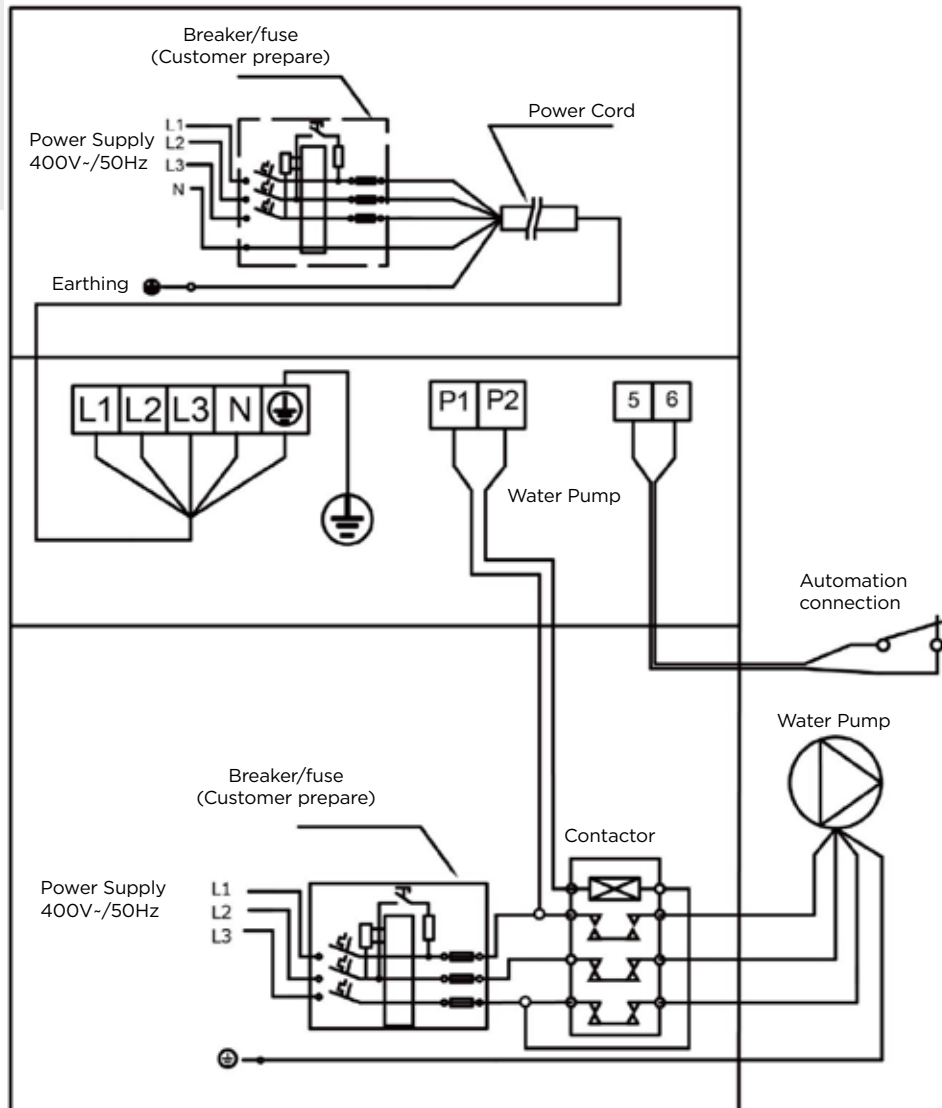

Water pump control and timer connection

1: Water pump timer

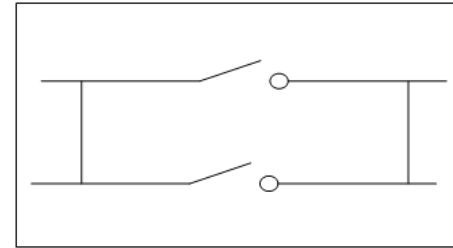

2: Water pump wiring of Heat Pump

Note: The installer should connect 1 parallel with 2 (as above picture). To start the water pump, condition 1 or 2 is connected. To stop the water pump, both 1 and 2 should be disconnected.

Usage Of Chemical Products

When adding chemicals to your pool or spa, follow the manufacturers guidelines for application and dosing levels.

Allowing high concentrations of chemicals through the heater should be avoided. Resultant damage may be inflicted on the heater.

Water quality standards that must be strictly adhered to*:

DESCRIPTION	NORMAL RANGE*	VERIFY
PH Level	7.2 - 7.6	1 per week
Chlorine Concentration	2 - 5 PPM	1 per 2-3 days
Total Alkalinity	80 - 150 PPM	1 per 2-3 weeks
Total Dissolved Solids	Below 1500 PPM Reg Pool Below 7500PPM Salt Pool	1 per month 1 per month
Calcium Hardness	200 - 300 PPM	1 per month
Salt Level	4000 - 6000 PPM	

* Warranty can be voided if not maintained within these ranges.

Performance Specifications

PERFORMANCE CONDITION: Air 27°C/ Water 27°C/ Humid. 80%		
Turbo Mode	Heating capacity (kW)	60.0
Perfect Mode	Heating capacity (kW)	48.5
	COP range	7.5-15.1
	Average COP at 50% Speed	12.0
PERFORMANCE CONDITION: Air 15°C/ Water 26°C/ Humid. 70%		
Turbo Mode	Heating capacity (kW)	42.0
Perfect Mode	Heating capacity (kW)	34.0
	COP range	5.6-8.1
	Average COP at 50% Speed	7.5
PERFORMANCE CONDITION: Air 35°C/ Water 28°C/ Humid. 80%		
Cooling capacity (kW)		25.0
TECHNICAL SPECIFICATIONS		
Rated input power (kW)		1.88-7.50
Rated input current (A)		2.72-10.87
Sound level at 1m dB(A)		51.0-59.0
Sound level 50% at 1m dB(A)		53
Sound level at 10m dB(A)		30.0-39.0
Operating air temperature (°C)		-20-43°C
Compressor		Mitsubishi DC Inverter Compressor
Heat exchanger		Twisted Titanium Heat Exchanger
Fan direction		2 X Horizontal
Power supply		400-415V/ 3 Ph/ 50Hz
Water Flow Rate (LPM)		330 - 400
Water connection (mm)		65mm slip
Net dimension LxWxH (mm)		459 X 1545 X 1630
Refrigerant		R32 - 4800 grams

Wi-Fi Operation

IMPORTANT

NOTE: It is essential the heat pump is able to connect to the premise wifi signal. Premise owners are responsible for supplying a strong wifi signal to the area the heat pump will be installed to ensure the app functionality operates correctly.

1 InverGo Download



2 Account Registration

Register by e-mail or third-party application.



a. E-mail registration

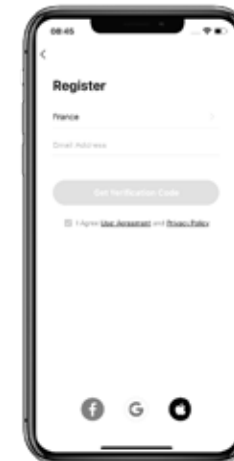

Wi-Fi Operation

b. Register through third-party application

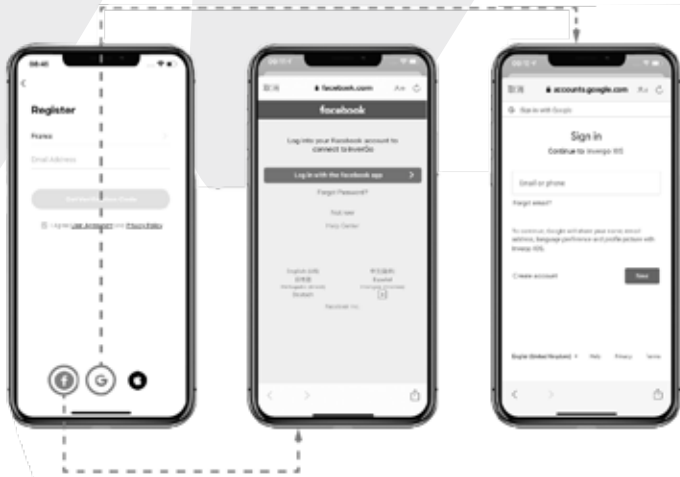

3 Create Family

Please set family name and choose location of device.

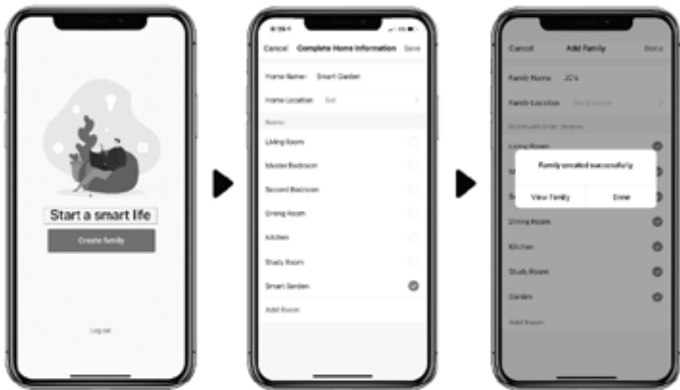

Wi-Fi Operation

4 APP Pairing

a. With Bluetooth

1. Please confirm that you're connected to Wi-Fi and your Bluetooth is on.
2. Click "Add Device", and then follow the instructions to pair device.

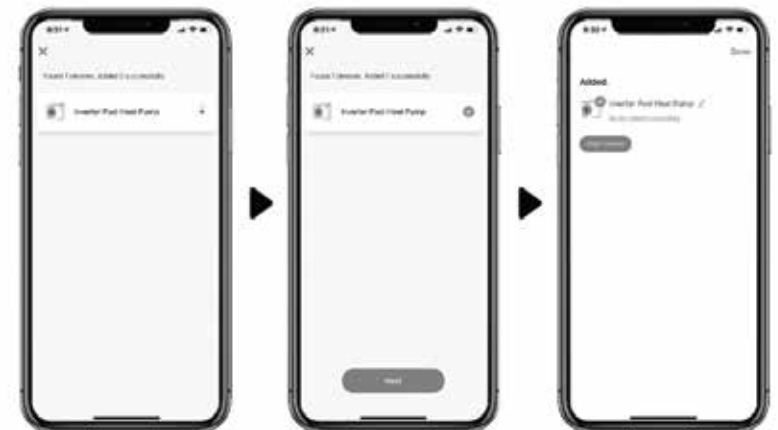

Wi-Fi Operation

a. With Wi-Fi

1. Please make sure you are connected to Wi-Fi.
2. Press “

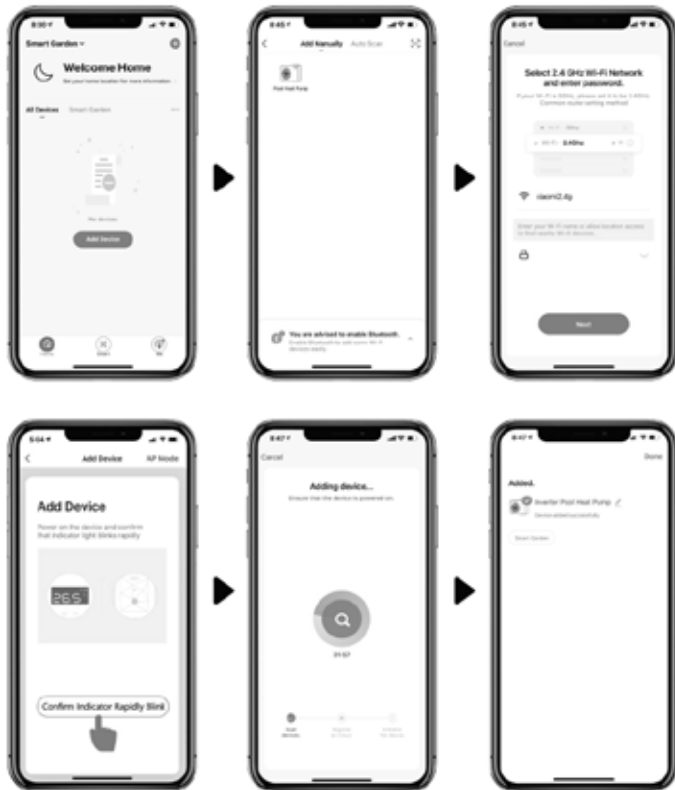

Wi-Fi Operation

5 Operation

1. For heat pump with Heating function only:

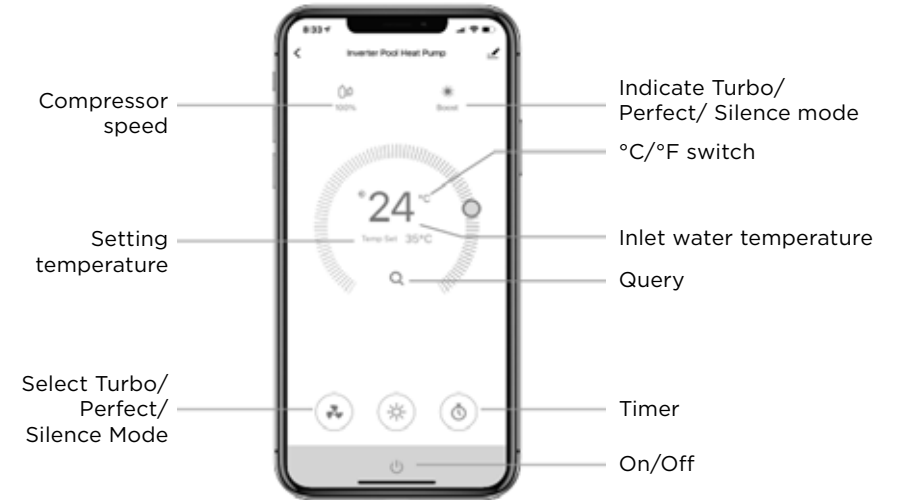

2. For heat pump with Heating & Cooling function:



Wi-Fi Operation

6 Share Devices to Your Family Members

After pairing, if your family members also want to control the device, please let your family members register “InverGo” first, and then the administrator can operate as below:

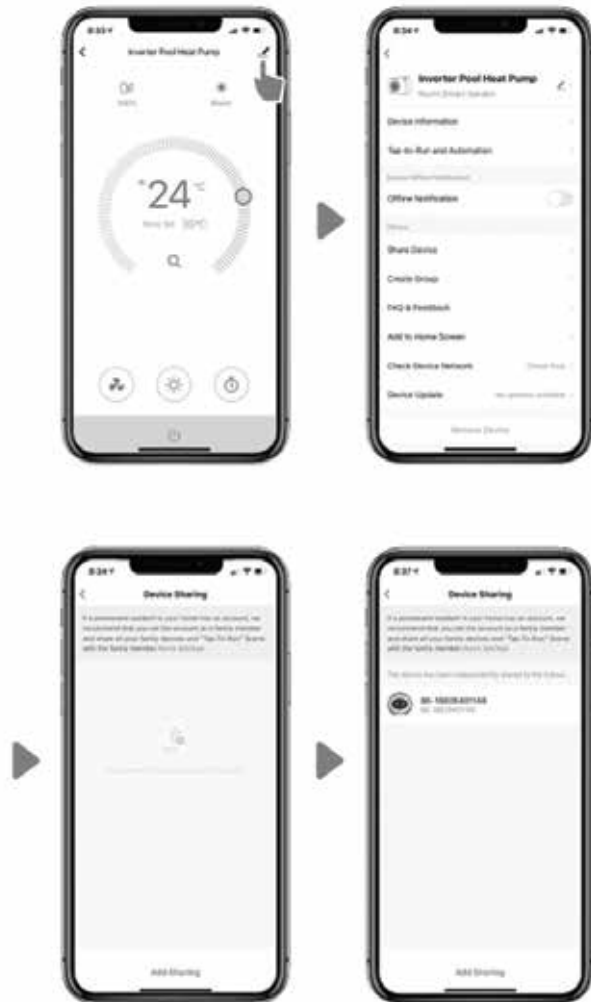

Notice:

1. Weather forecast is just for reference.
2. App is subject to updates without notice.

OPERATION OF YOUR POOL HEAT PUMP

Initial Heating

To achieve initial heating, your pool heat pump and the pool pump may require extended operation until desired temperature is achieved. The initial heating time may vary depending upon the five factors listed below. After initial heating, operating time may be reduced to match daily heat loss.

1. Size of the pool.
2. How many degrees the water is to be heated.
3. Ambient air temperature - the warmer the air, the less time required to heat.
4. Use of a solar blanket.
5. The size of the pool heat pump.

If a combination of the atmospheric and water temperatures are below the minimum listed concurrently the pool heat pump should not be operated and be switched off.

Generally, atmospheric conditions (air temperature) will be warmer during day time hours. To accelerate the initial heating period owners may opt to increase the ambient air temperature artificially around the evaporator area of the pool heat pump until the pool water temperature has reached the minimum required as stated below.

Model	Atmospheric conditions must be above	Pool water temperature must be above
Electroheat PRO 60	0°C / 32°F	10°C / 50°F

Adjustment Of The Bypass Valves

Waterco PRO 60 pool heat pumps do not require the water by pass valves adjusted to cope with cooler water temperatures. In the event of low water temperatures, the PRO 60 inverter pool heat pumps increase the operating frequency of the compressor which in turn increases the output capacity of the unit.

It is essential water flow through the unit is within the range specified in the Performance Specifications table on page 17. The bypass valve may be used to tune the water flow within range.

The adjustment may vary according to pool pump size.

Pool Heat Pump Running Time

Most units should be sized to operate during the pool filtering cycle time of 8-10 daytime hours daily during warmer months and up to 8 hours daily during the daytime in winter months. On warmer days the pool heat pump will run less because the heat loss will be less.

IMPORTANT

Condensation

Your pool heat pump will accumulate condensed water (approx. 4 to 6 litres or 1 to 1.5 gallons per hour), therefore causing water to drain out of the unit base. In order to avoid water accumulation, you may use decorative rocks around the concrete slab or a basin under the unit. (Please note this is a normal characteristic of a pool heat pump and not a service or warranty issue.)

The inlet and outlet water unions can't stand the weight of soft pipes. The heat pump must be connected by hard pipes!

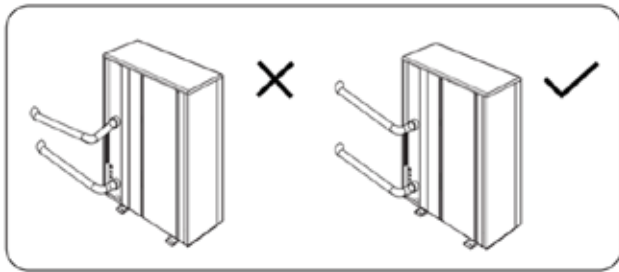

Pool Solar Blanket

A pool solar blanket should be used whenever possible. Blankets minimize heat loss through evaporation and conserve heat in your pool. Un-blanketed pool can lose 2-3 times more heat than a blanketed pool.

Defrost Cycle

When any of the following conditions occur the electronic control of your unit will activate a defrost mode until most of the frost from the evaporator has melted. Condensation of water on the evaporator coil tends to frost up quicker when the following occur.









1. When atmospheric conditions are as stated above;
2. When the evaporator is dirty;
3. When installation clearances are not respected.

Defrost is activated for between 3 to 20 minutes.

Operation Guide

1. Key Function



Symbol	Heating & Cooling Modes
	<ol style="list-style-type: none"> 1. On/Off 2. Wi-Fi setting
	<ol style="list-style-type: none"> 1. Lock/Unlock Screen 2. Heating mode (18-40°C) 3. Cooling mode (12-30°C) 4. Auto mode (12-40°C)
	<ol style="list-style-type: none"> 1. Turbo  2. Perfect  3. Silence 
 	Temperature Setting

Attention:

- i. The controller has power-down memory function.
- ii. The buttons will turn dark when it's locked.

2. Screen Display

a. Plugged without turning on



b. Power on Heating & cooling



	Heating mode
	Cooling mode
	Auto mode
	Running speed percentage
	Wi-Fi connection
	Inlet
	Outlet

3. Operation Instruction

a. Screen Lock

1. There is automatic screen lock function. No operation for more than 30 seconds, screen will automatically lock, and screen will dim while the lock button will light on, and other button light will be off.
2. Press “” for 3 seconds to unlock the screen; screen and buttons will light on.
3. Press “” for 3 seconds to lock the screen; screen will be dark; lock button lights on and other buttons will light off.
4. Only “” works under off-screen; other buttons work after screen on.
5. Lock Period: only “” lights on. If with Wi-Fi, “” and “” light on.

b. Power On

1. Press “” for 3 seconds to unlock screen. Press “” to power on machine

c. Temperature Setting

1. Press “” and “” to display and set temperature under screen on.

d. Mode Selection

1. Heating/Cooling/Auto
Press “” to switch among heating “”, cooling “” and auto mode “”.
2. Heating mode “”: Water temperature setting range(18-40°C)
3. Cooling mode “”: Water temperature setting range(12-30°C)
4. Auto mode “”: Water temperature setting range(12-40°C)

* When water inlet temperature is higher than setting point, automatic cooling mode starts.
* When water inlet temperature is lower than setting point, automatic heating mode starts.

e. Turbo/Perfect/ Silence mode

Heating mode: Press “” to switch among Turbo mode , Perfect mode and Silence mode .

Cooling and Auto mode: only support Turbo mode , Perfect mode .

3. Operation Instruction

f. Operating frequency

Compressor icon lights on during operation. Operation frequency speed will be showed on screen as below:



g. Wi-Fi

1) Wi-Fi connection

When the screen is on, press “

Connect Wi-Fi on mobile phone and input password, and then control equipment by Wi-Fi. When APP connects Wi-Fi successfully, “



2) WIFI reset (WIFI password change or the network configuration change)

Press “

3) “

3. Operation Instruction

h. Defrosting

1. Automatic defrosting: When machine is auto defrosting,  will flash, and return to previous working mode when it finishes.
2. Manual Defrosting: To enter forced defrosting mode, the compressor must be working more than 10 minutes. in heating mode, press “

(Remarks: the interval between each manual defrosting should be more than 35 minutes.)

Operation and exit condition of Automatic and Manual defrosting is same.

i. Advanced applications (Professional operation)

1) Running Status Checking

Press “

Running status checking table:

Symbol	Content	Unit
C0	Inlet water temp	°C
C1	Outlet water temp	°C
C2	Ambient temp	°C
C3	Exhaust gas temp	°C
C4	Evaporator coil pipe temp	°C
C5	Return gas temp	°C
C6	Cooling coil pipe temp	°C
C9	Cooling plate temp	°C
C10	EEV opening angle	P
C11	DC motor fan speed	r/min

MAINTENANCE OF YOUR POOL HEAT PUMP

Waterco pool heat pumps have been specifically engineered to give you years of satisfaction and enjoyment in the pool.

Cabinet Cleaning

To clean the plastic and painted surfaces use mild soapy water and a soft clean cloth. Never use solvents or abrasives.

Cleaning Evaporator

The evaporator at the rear of the unit must be kept clean and un-obstructed in order for your pool heat pump to have better efficiency and avoid problems which may void your warranty. The dirt collected in the evaporator can be removed with a gentle water spray and the use of a soft brush. Be careful not to damage the aluminum fins.

Cleaning drainage holes

The condensate drainage holes in the base of the unit must be kept free of debris. Blocked drainage holes may cause water to collect in the unit and become stagnant or, interfere with electrical components and wiring.

Issues caused by blocked drainage holes in the base of the unit are not covered under warranty.

Units Located In Coastal Locations

Care and maintenance procedures for Waterco Pool Heat Pumps installed in coastal locations.

Exposure to salt may result in evaporator coil damage shortening the life of the equipment.

Electroheat Pro 60 pool heat pumps are fitted with evaporators treated with hydrophilic blue fin technology. The advantages are:

The epoxy coating on the coils prevents accumulation of salt, acid, dust and water deposits which minimises the effects of corrosion.

Hydrophilic blue fin condensers do not allow water droplets to accumulate which can increase the efficiency of the pool heat pump.

Pool heat pumps located within 1 kilometre from the coast should be given a monthly rinse with potable water straight from the garden hose connected to the municipal water system to remove the salt build up on the evaporator coil and exposed metal surfaces.

Winterising Procedure

⚠ VITAL

If the pool heat pump is stored in a place where the temperature drops below the freezing point of 0°C / 32°F; it is **mandatory that the water accumulated in the pool heat pump be drained completely before freezing weather prevails. Improper winterizing may damage the pool heat pump and will void the warranty.**

- Turn the pool heat pump **“OFF”**.
- Turn the pool heat pump breaker **“OFF”**.
- The water piping **MUST** be disconnected to drain the pool heat pump's heat exchanger in preparation for winter.
- Once the piping is disconnected, the pool heat pump's heat exchanger **MUST** be emptied; the use of a water vacuum cleaner is strongly recommended or if you do not have this tool you may tilt the unit (75°) until all the water is out.
- It is recommended that pool heat pump's heat exchanger is rinsed out with a gentle water spray at the inlet and outlet water connections of the pool heat pump and then drain the heat exchanger again.
- With the help of 2 pool return winter plugs, block the water Inlet and Outlet connections to prevent access by vermin.
- Clean the drainage holes located at the bottom of the base of the unit.
- Unit may be covered for the winter.
- It is also possible to fill the heat exchanger with pool anti-freeze, but ensure that the antifreeze contains an elevated pH to prevent corrosion. This is optional and requires appropriate hardware.

GENERAL SAFETY INSTRUCTIONS

DO NOT DEPRIVE YOUR POOL HEAT PUMP OF WATER FLOW FOR MORE THAN 24 HOURS WITHOUT DRAINING IT. Make sure you leave the bypass valves as shown in Figure 1.

At the end of each season, when the pool heat pump is no longer in use, and proper pool water chemistry is not maintained, it should be disconnected from the water line and drained to prevent any possible corrosion or damage to the pool heat pump. Refer to Figure 1 below or winterising procedure (page 32).

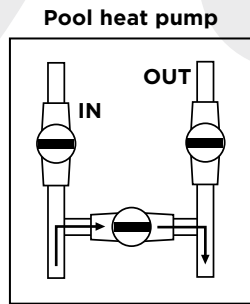

When your valves position are as shown on Figure 1, the water is bypassing the pool heat pump.

Figure 1

The valves shown above may be different to the ones installed on your system. Please ensure you understand how your bypass valve operates.

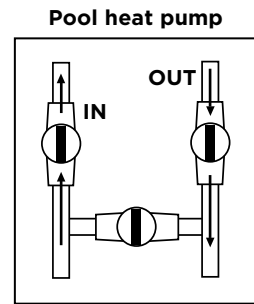

When your valves position are as shown on Figure 2, the water is going through the pool heat pump.

Figure 2

TROUBLESHOOTING

Please ensure the unit and any related equipment is installed in accordance with the installation manual. If not, the Waterco warranty will not apply and the customer may be liable for service call charges.

Nothing Is Working And The Electronic Control Does Not Operate

1. Ensure the circuit-breaker has not tripped and/or the fuses have not blown;
****Take note that only an electrician can verify if the circuit breaker is defective; if this is the case, repairs will not be covered under the warranty.**
2. For three phase models, this situation could occur when phases are not in the appropriate order.
 Please have a qualified electrician swap over two of the incoming phase wires.

Nothing Is Working But The Electronic Control Temperature Displays Digits Or A Code

1. Identify the analyser code that the electronic control displays and refer to the Service Analyser codes section;
2. If the electronic control displays digits, make sure that the electronic control is programmed correctly, refer to the Operation of your pool heat pump and reprogram if necessary.

***Note that this situation could occur when the electrical voltage is not respected as stated on the pool heat pump name plate. This situation is not covered by the manufacturer warranty.*

Fan Doesn't Work (the fan blades are not moving)

1. IMPORTANT: For safety, switch OFF the circuit-breaker.
2. Try to rotate the fan blades of the fan with a rod to see if the motor is jammed or seized
3. If the fan blades do not turn freely leave the unit switched OFF and call for service;
4. If the fan blades turn freely switch ON the circuit breaker and the pool heat pump again.

*** Note that your fan motor may have an electrical fault if the blades turn freely when the unit is switched OFF and does not start when the unit is switched ON.*

Fan Blades Turn, But Compressor Is Not Functioning

The pool heat pump has a built in delay timer which prevents the compressor from starting immediately. The delay can be 3 to 5 minutes in duration after the fan blades have turned. Furthermore if the unit is in defrost mode the compressor will not start for 3 to 20 minutes.

1. Check that air being discharged from the fan blades is colder than the ambient air. If the air being discharged by the fan blades is colder, it means that the compressor is functioning correctly.
2. Turn off the pool heat pump then immediately turn it back on;
3. As soon as the fan blades start turning, wait a minimum of 3-5 minutes. The compressor should start up after this time and you will be able to identify a different sound made by the compressor when it starts;
4. If the compressor is functioning, but shuts off immediately, consult the following section "Compressor Starts and Stops".
5. If the problem persists, call your local Waterco office for assistance.

Compressor Starts And Stops

1. Check that the unit has been installed correctly (refer to installation procedures).
2. Check that the water inlet and outlet of the unit have not been connected incorrectly.

There Is Water Around The Pool Heat Pump

It is a normal occurrence for water condensation, to be seen running from the unit base. There will be on average 4 to 6 litres of condensed water per hour being discharged from the unit base. In order to avoid water accumulation, you may use decorative rocks around the concrete slab or a basin under the unit. Be sure that clearances around the unit are respected.

To test the unit and confirm you have no pool water leaking from the unit perform the following test which is best performed early in the morning and continuing for the whole day:

1. Turn off the pool heat pump from the circuit breaker and the pool pump.
2. Open the bypass valve. (refer to drawing on page 5)
3. Close the **IN** and **OUT** water valves on the unit.
4. Restart the pool pump. The pool heat pump must remain **OFF**.
5. When all of the water around the base of the pool heat pump has dried, open the water **IN** and water **OUT** valves on the pool heat pump.
6. Close the bypass valve to allow full water flow through the pool heat pump.

If water is now seen running from the outside of the pool heat pump or inside the pool heat pump after a short period of time you should call for service. If no water is seen after a short period of time it would be assumed the water was condensation which is normal.

Pool Heat Pump Has Ice Formed On The Evaporator Coil

1. **IMPORTANT:** For safety, switch OFF the circuit-breaker.
2. Allow the ice to melt and then inspect the evaporator to ensure it is free of debris and leaves.
3. If the evaporator is dusty or dirty, clean it with a light spray of water and allow it to dry (do not use high pressure it may damage the evaporator fins).
4. When the unit is dry, you may switch it back ON from the circuit breaker.
5. Ensure that the clearances around the unit are respected.
6. When the unit has been switched ON ensure the fan motor is working (fan blades will be turning) while the compressor is operating.
7. If the fan blade does not turn and the compressor is functioning; notify customer service.

***If the pool heat pump requires service, the owner of the pool heat pump will need to ensure the unit has been switched OFF to allow any ice to melt prior to any technician attending.*

Pool Heat Pump Is Functioning, But Does Not Reach The Desired Temperature Setting

IMPORTANT

Improper installation may cause this situation and will need to be corrected by the owner.

1. Ensure the by-pass valves are in the correct positions to ensure sufficient water flow, insufficient water flow will cause the compressor to shut off early.
2. If you have installed a timer or the pool heat pump is equipped with an integrated timer, be sure it is programmed to allow the pool pump to work for sufficient time in order to reach the programmed temperature.
3. Ensure the evaporator is cleaned regularly with a light spray of water and allowed to dry before re-starting the pool heat pump to avoid premature ice build up on the evaporator.
4. Waterco recommend the use of a solar cover to retain heat in pool water. Pools without covers lose 2 to 3 times more heat than pools with solar covers.
5. Make sure the electronic control of your pool heat pump has been programmed correctly; during this test the pool heat pump and water pump must be working continuously (eg; the desired water temperature must be set correctly).
6. If the unit continually fails to reach the desired water temperature, the unit may be undersized due to geographic location, volume of pool, set temperature is higher than what the heat pump was sized at, the pool may be in a windy location which was not allowed for or the heat pump is being used in winter when it was sized for summer operation.

Circuit Breaker Trips

IMPORTANT

If you have purchased a remote control (or other equipment), ensure the equipment is correctly installed. If an operational issue originates from incorrect operation or installation of this equipment, Waterco's warranty will not apply and you will have to pay the cost of the service call.

1. The amperage of the circuit breaker AND the electrical wiring must be as the instructions on the pool heat pump name plate, otherwise notify your installer or electrician to correct this problem, as this is not covered under the warranty.
2. If the circuit breaker and electrical wiring are as stated, make sure the drains, located under the base of the pool heat pump are not obstructed.

The Pool Heat Pump Is Noisy

1. Check the pool heat pump is level and on a solid base to prevent any vibrations issues.
2. Ensure the noise is coming from the pool heat pump, not from other equipment which will not be covered by the warranty (for example: noise coming from the bypass valve, pool pump, etc);
3. An improper installation may cause this situation it will need to be corrected by the owner.

The Temperature Shown On Pool Heat Pump Is Not The Same That Is Shown By The Pool Thermometer

It is possible to have a temperature variation between the temperature shown on the electronic control temperature display of the pool heat pump and a pool thermometer which may be read from different locations.

- Check that there are no leaks on the pool plumbing (there should be no air leaks in the pipework);

Dimension

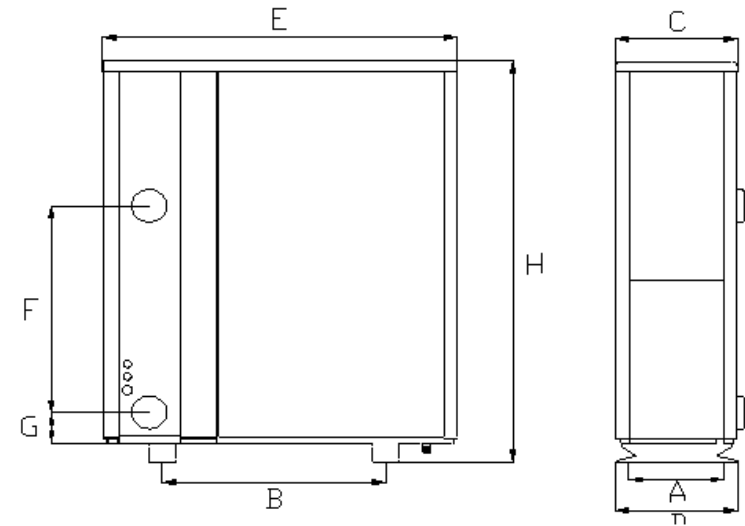

Size(mm)	Name	A	B	C	D	E	F	G	H
Model									
	IMC60WAT	391	1055	458	459	1545	840	123	1630

*Above data is subject to modification without notice

Note: Above swimming pool heat pump specification drawing is for installation reference only to technical staff. is subject to modification without notice

Failure solution and code

Failure	Reason	Solution
When powered on, the controller displays a code	Startup code	This is normal. Please wait until it disappears.
Unresponsive controller	Some models have screen lock function.	Refer to the manual to unlock the screen
Heat pump doesn't run	Improper operation	Refer to the manual
	No power	Wait until the power recovers
	Unit is powered off	Switch on the power
	Burned fuse	Check and change the fuse
	The breaker is off	Check and turn on the breaker
	Voltage anomaly	Inspection by professional
Unit suddenly starts or stops running	The unit may be in defrost. At this point the fan stops spinning and the heat indicator on the controller will flash	Not failure, the unit will switch back after defrosting
	Some models have a timed power on/off function.	Refer to the manual to disable this function
	Once the set temperature is reached, the heat pump will go into standby	This is normal
Air is blowing out, but unit is not heating well	Evaporator blocked	Clear the blockage
	Air inlet and/or outlet blocked	Clear the blockage
	3 minutes start delay protection for compressor	Wait patiently
Display normal, but no heating	Set temperature too low	Set to proper temperature
	3 minutes start delay protection for compressor	Wait patiently
Unit is releasing white smoke	The unit is defrosting	This is normal. Please wait until unit finished defrosting.
Unit is leaking water	In heating mode, condensation will be generated on the evaporator and released through the bottom of the unit	This is normal
If above solutions don't work, please contact your installer with detailed information and your model number. Don't try to repair it yourself		

Note: If the following conditions happen, please stop the machine immediately, and cut off the power supply immediately. Then contact your dealer:

1. Unit has stopped running because of external factors
2. The fuse is frequently broken or leakage circuit breaker jumped.

Protection & Failure Code

NO.	Display	Protection code description
1	E3	No water protection (not failure)
2	E5	Power supply excesses operation range
3	E6	Excessive temp difference between inlet and outlet water(Insufficient water flow protection)
4	Eb	Ambient temperature too high or too low protection (not failure)
5	Ed	Anti-freezing reminder (not failure)
NO.	Display	Failure code description
1	E1	
2	E2	Low pressure protection
3	E4	3 phase sequence protection (three phase only)
4	E7	Water outlet temp too high or too low protection
5	E8	High exhaust temp protection
6	EA	Heat exchanger overheat protection/Evaporator overheat protection (only at cooling mode)
7	P0	Controller communication failure
8	P1	Water inlet temp sensor failure
9	P2	Water outlet temp sensor failure
10	P3	Gas exhaust temp sensor failure
11	P4	Evaporator coil pipe temp sensor failure
12	P5	Gas return temp sensor failure
13	P6	Cooling coil pipe temp sensor failure
14	P7	Ambient temp sensor failure
15	P8	Cooling plate temp. sensor failure
16	P9	Current sensor failure
17	PA	Restart memory failure
18	F1	Compressor driver module failure
19	F2	PFC module failure
20	F3	Compressor start failure
21	F4	Compressor running failure
22	F5	Inverter board over current protection
23	F6	Inverter board overheat protection
24	F7	Current protection
25	F8	Cooling plate overheat protection
26	F9	Fan motor failure
27	Fb	Power filter plate No-power protection
28	FA	PFC module over current protection

WARRANTY

1. Waterco's obligation to repair or replace at Waterco's option, shall be the original purchaser's sole and exclusive remedy under this warranty. Waterco shall not be liable for incidental, consequential or special damages arising out of or in connection with product use or performance.
2. Waterco is not responsible for direct or indirect damages resulting from defective components. This warranty gives you specific legal rights and you may also have other rights, which vary from state, province or country to another.
3. Prior to contacting Waterco for assistance or service, please check the "Troubleshooting" and the information stated in this section.
4. Warranty will only cover manufacturing defects. All service call requests which are not of this nature must be paid by the purchaser to the service company authorized by Waterco.
5. All services will be handled by the authorized service company. Warranty may be voided if service is not carried out by a Waterco authorised service agent.
6. **DO NOT** return the pool heat pump to your dealer as they do not provide the service work.
7. Prior to contacting Waterco for assistance or service, in order to qualify for a warranty claim, the original purchaser must have the model name and serial number along with a proof of the original purchase date. Proof of purchase must be forwarded to Waterco and they will inform you of the applicable warranty.
8. Once connected with a Waterco customer service agent, proceed to describe in detail the issue associated with your pool heat pump. If a permanent code appears on the electronic control panel, please advise the Waterco service agent.
9. There are no other warranties, express or implied, including, but not limited to, implied warranties of merchantability or fitness for a particular purpose. During warranty period, Waterco will, at its option, repair or replace, without charge, any product or part, which is found to be defective under normal use and service.

IMPORTANT: The warranty is not transferable and no action can be exercised by a consumer subsequent purchaser of the pool heat pump.

Waterco does not guarantee and will not pay for:

A. Service calls to:

1. Inspect and/or correct the installation of your pool heat pump.
2. Instruct you on how to use your pool heat pump.
3. Replace house fuses or correct power supply problem.
4. Adjust or reestablish water flow to the pool heat pump.

B. When a service call with no manufacturing problem has been detected, on site, by the service company mandated by Waterco.

This Warranty does not cover:

- A. Damage, issues or unsatisfactory performance caused to the equipment by faulty or incorrect external electrical wiring, incorrect power supply, voltage fluctuations, over voltage transients or electromagnetic interference not originating within the equipment.
- B. Damage, issues resulting from incorrect or poor installation.
- C. Failure to provide adequate ventilation for the unit.
- D. Damage or deterioration to the external surfaces or refrigeration coils caused by normal weathering or corrosive atmospheric conditions.
- E. Damage, issues caused by the use of an accessory, component or equipment not supplied by Waterco.
- F. Any costs or additional labour associated with gaining acceptable service access to equipment installed in restricted or unsafe (e.g. high) locations.
- G. Freight charges (including insurance) or travelling cost for repairs performed outside the area normally serviced by Waterco or authorised repair agent.
- H. Any consumable item (e.g. batteries, filters) supplied with the equipment unless the item is shown to be defective at the time of purchase.
- I. Damage, issues or unsatisfactory performance resulting from operation in an environment where the climatic comfort of humans is not the primary function of the equipment. Damage, issues or unsatisfactory performance resulting from operations at conditions outside the operating conditions specified in the Waterco technical or sales literature applicable to the equipment.
- J. Damage, problems or unsatisfactory performance resulting from misapplication of the equipment.
- K. Equipment installed in a transportable or

Visit www.waterco.com.au/customer-service/warranty-terms for our full Warranty Terms and Conditions.