

WATERCO POOL HEAT PUMP

Electr  Heat
ECO-V 38, 39 & 48kW

Installation and Operation Manual



WARNING

This equipment must be installed and serviced by a qualified technician.

Improper installation can create electrical hazards which could result in property damage, serious injury or death. Improper installation will void the warranty.



Notice to Installer

This manual contains important information about the installation, operation and safe use of this product. Once the product has been installed **this manual must be given to the owner/operator of this equipment.**

Table of Contents

IMPORTANT SAFETY INSTRUCTIONS	02	MAINTENANCE OF YOUR POOL HEAT PUMP	19
A NOTE TO YOU	03	Cabinet Cleaning	19
INSTALLATION INSTRUCTIONS	05	Cleaning Evaporator	19
Location	05	Cleaning drainage holes	19
Installation Clearances	06	Units Located In Coastal Locations	19
Water Piping	07	Winterising Procedure	20
Water Flow Rate	07	GENERAL SAFETY INSTRUCTIONS	21
Water By-pass Kit	07	TROUBLESHOOTING	22
Plumbing Diagram	08	Nothing Is Working and The Electronic Control Does Not Operate	22
Electrical	09	Nothing Is Working But The Electronic Control Temperature Displays Digits or a Code	22
Electrical Connection	09	Fan Doesn't Work (The Fan Blades Are Not Moving)	22
Breaker Size	09	Fan Blades Turn, But Compressor Is Not Functioning	23
Electrical Wire Size	09	Compressor Starts and Stops	23
Bonding	10	There Is Water Around The Pool Heat Pump	23
Bonding Diagram	10	Pool Heat Pump Has Ice Formed On The Evaporator Coil	24
Remote Control Connections	11	Pool Heat Pump Is Functioning, But Does Not Reach The Desired Temperature Setting	24
Usage Of Chemical Products	12	Circuit Breaker Trips	25
Refrigerant Charge Indicator Gauge	12	The Pool Heat Pump Is Noisy	25
Performance Specifications	13	The Temperature Shown On Pool Heat Pump Is Not The Same That Is Shown By The Pool Thermometer	25
OPERATION OF YOUR POOL HEAT PUMP	14	Dimensional drawing of heat pump	26
Initial Heating	14	Electric Circuit Drawing	27
Adjustment Of The Bypass Valves	14	Service Parameters Tables	28
Pool Heat Pump Running Time	15	Parameter Number and Description Table	29
Pool Solar Blanket	15	WARRANTY	31
Defrost Cycle	15		
INVERTER POOL HEAT PUMP CONTROLLER ..	16		
Illustration for LCD Display	17		
Working Modes	17		
Time Setting	17		
Water Temperature Setting	17		
Water information	18		
Operation Modes	18		
Memory Function	18		

IMPORTANT SAFETY INSTRUCTIONS

When using this electrical equipment, basic safety precautions should always be followed, including the following:

READ AND FOLLOW ALL INSTRUCTIONS

! WARNING: Disconnect all AC power during installation and servicing.

! WARNING: In order to avoid the possibility of hyperthermia (heat stress) occurring it is recommended the average temperature of the spa - pool water does not exceed 40°C / 104°F.

! WARNING: The pool heat pump is not intended for use by persons (including children) with reduced physical sensory or mental capabilities, or lack of experience and knowledge, unless they have been provided supervision or instruction concerning use of the appliance by a person responsible for their safety. Children should be supervised to ensure they do not play with the appliance.

- In certain situations unexpected start up may occur when the appliance is in automatic mode.
- The installer should assess the risk associated with unexpected start-up of this device which, in any circumstance should have no hazardous effect.
- The pool heat pump is not meant to provide safety protection for other devices.
- The pool heat pump should be deactivated if the pool or spa has been drained.
- Waterco pool heat pumps must be installed by a suitably qualified person in accordance with current Regulatory Standards, the applicable Wiring Rules (AS3000) and local statutory authority regulations.
- Parts containing live parts, except parts supplied with safety extra-low voltage not exceeding 12V, must be inaccessible to a person in the spa - pool.
- Parts incorporating electrical components, except remote control devices, must be located or fixed so that they cannot fall into the spa - pool.
- The appliance should be supplied through a residual current device (RCD) having a rated residual operating current not exceeding 30mA.
- An Earth terminal is located inside the wiring enclosure. To reduce the risk of electric shock, this terminal must be connected to the grounding means provided in the electric supply service panel with a continuous copper wire as sized to comply with current Standards and local statutory authorities in relation to the circuit conductors supplying the equipment.
- A cable connector is provided on this unit to connect a suitably sized copper conductor between this unit and any metal equipment, metal enclosures of electrical equipment, metal water pipe, or conduit within 1.5m of the unit via equipotential bonding.

SAVE THESE INSTRUCTIONS.

A NOTE TO YOU

Congratulations!

Thank you for choosing a Waterco Electroheat ECO-V inverter heat pump to heat your pool.

Using the latest technology in heat capture, the Waterco pool heat pump converts the energy released by the sun and transfers it efficiently to your swimming pool.

During certain periods it may be necessary to operate your pool heat pump continuously during the day in cooler periods however, this should not be of concern as your Waterco pool heat pump can heat up your pool approximately 80% more economically than the fossil fuel heating or heaters with electric elements. Waterco pool heat pumps are designed specifically to heat or cool your swimming pool economically.

To appreciate the benefits this product will bring you, make sure to operate the unit when the atmospheric conditions specified in this document are present in addition of using a solar blanket to minimize heat loss which will influence operating costs and size of the unit required. Pools not covered with a solar blanket lose 2 to 3 times more heat, regardless of types of heating!

This manual applied to the following models:

Electroheat ECO-V 39kW - heat / cool with automatic evaporator de-icing (single phase)

Electroheat ECO-V 38kW - heat / cool with automatic evaporator deicing (three phase)

Electroheat ECO-V 48kW - heat / cool with automatic evaporator deicing (three phase)

Transportation and Storage

1. The heat pump **MUST** be transported and stored **VERTICALLY!**
2. The heat pump **MUST** be transported and stored upright on a pallet with good package.



Record your model's information.

Keep this manual and your original proof of purchase receipt for warranty and future reference.

On the base of your pool heat pump is a name plate which contains information such as model number, serial number and electrical information.

Please write these down below and have them handy incase of a service call request.

Model Number _____

Serial Number _____

Purchase Date _____

Dealer Name _____

Dealer Address _____

Dealer Phone _____

To find detailed product information, the location of the nearest dealer or to register your pool heat pump please visit our website www.waterco.com and select your location.

INSTALLATION INSTRUCTIONS

Location

To gain maximum efficiency for your pool heat pump please follow all instructions when “positioning the unit”. It is also important to allow clearances for future service and maintenance procedures.

The unit is designed for outdoor installation and should not be installed in a totally enclosed area such as a shed, garage, etc., unless ducted and fan assisted ventilation of the cold exhaust air is provided to ensure adequate air exchange for correct operation. Re-circulation of cold discharged air back into the evaporator coil should be avoided and will greatly reduce unit’s heating capacity and efficiency.

The unit should be located as close as practically possible to the existing pool pump and filter to minimize water piping. The use of 90 degree bends and short radius elbows in the water piping should be kept to a minimum.

Mount the unit on a sturdy base, preferably a concrete slab or blocks. The base should be completely isolated from the building foundation or wall to prevent the possibility of sound or vibration transmission into the building. The size of the base should not be less than the base of the pool heat pump.

Use of anti vibration mat between the base of the unit and final installation location material is highly recommended to reduce potential vibration noise issues.

Fitting the drainage spigots (if supplied) to the underside of the base must be installed prior to final installation of the unit.

The unit should be maneuvered into its final position and anti vibration mounts fitted under each foot. Each foot may then be bolted down to the concrete slab (supplied by other).

Installation Clearances

Air is pulled through the evaporator coil and discharged from the top grill. Clearances must be allowed in front and around the unit for unrestricted air discharge and service access. See Figure 1. Failure to comply to the set clearances may cause diminished unit performance and reduced unit longevity.

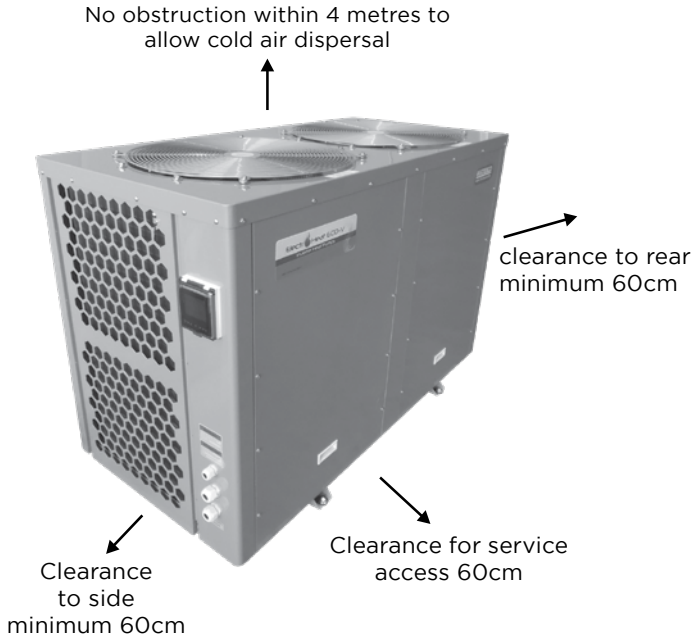

Figure 1

Water Piping

The supplied plumbing layout must be followed without exception:

1. pool pump
2. filter
3. pool heat pump
4. chlorinator (when installed).

Rigid PVC piping is recommended with all joints primed and glued with a suitable PVC adhesive cement. If rigid PVC pipe is not available, a suitable flexible hose of adequate diameter may be utilised with stainless steel clamps. When the piping installation is complete, operate the pool pump and check the system for leaks. Then check the filter pressure gauge to see that excessive pump head pressure is not indicated.

Water Flow Rate

The recommended water flow rate range varies depending on the size of the heat pump to ensure maximum heat transfer efficiency. The optimal flow rate is the mid point of this range. Use the bypass valve to adjust the flow rate to within the recommended range. The optimum water in / water out temperature differential is 2-3°C at 27°C ambient air temperature.

Waterco recommend FlowVis for precise flow measurement and tuning. See Performance Specifications table page 13.

Water By-pass Kit

A bypass kit consisting of 3 X two way valves must be installed for adjustment of water flow and ease of service.



Plumbing Diagram

⚠ VITAL

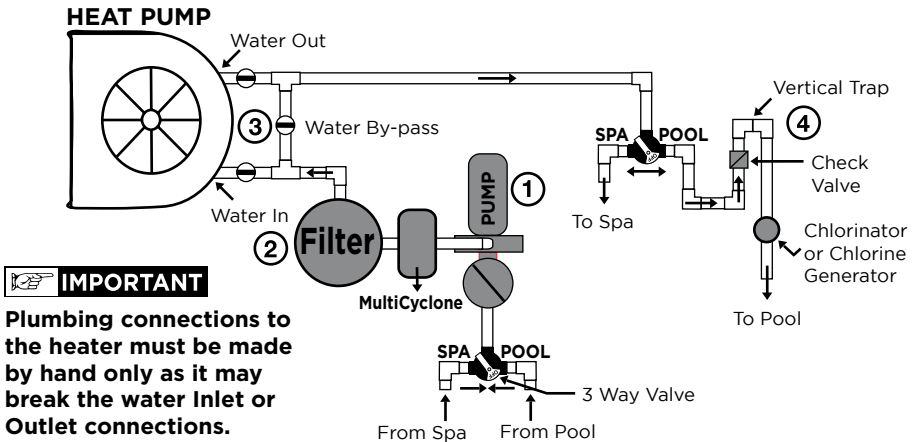

👉 IMPORTANT

Plumbing connections to the heater must be made by hand only as it may break the water Inlet or Outlet connections.

1. A check valve or a loop **shall** be installed between the pool heat pump and any automatic chlorinator to prevent highly chlorine concentrated water from flowing back to the pool heat pump when the pool pump is not running.
2. These units are fitted with a flow switch which are not effected by water pressure. Therefore, the fitment of a flow check valve due to the installed height either above or below water level is not required.
3. For units installed above the pool water level the return water to the pool valve on the bypass valve set should be closed approximately 15-20% to ensure the heat exchanger is completely full of water to allow the heat transfer to occur.

IMPORTANT

Electrical

All electrical work should be performed by a fully qualified and licensed electrician in accordance with local electrical codes.

An adequate circuit breaker and copper wiring must be used. Electrical requirements are available on the name plate of the pool heat pump. It may be necessary to install an earth leakage circuit breaker.

Waterco recommend connecting the unit to an isolating switch to allow ease of service and maintenance.

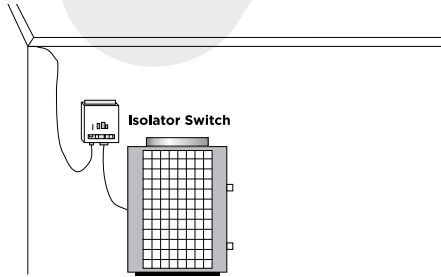

⚠ WARNING THE POOL HEAT PUMP MUST BE DISCONNECTED BEFORE OPENING THE ACCESS PANEL.

Electrical Connection

Standard 60 Hz power supply : 380 - 415V/3Ph/60Hz

Standard 50 Hz power supply : 230 - 240V/1Ph/50Hz, 380 - 415V/3Ph/50Hz

Electrical connections to the heat pump should be to the following terminals:

Single Phase L = Active N = Neutral E = Earth

Three Phase L1 - Phase 1 L2 - Phase 2 L3 - Phase 3 N = Neutral

E - Earth

P1 & P2 terminals are for switching a relay or contactor to operate a pump via a separate power circuit. These terminals are rated up to 500W.

Breaker Size

Please consult name plate on the base or the side of your pool heat pump for starting amperage and required breaker size.

Electrical Wire Size

Please consult a qualified and licensed electrician.

⚠ WARNING The power cable ground must be connected to the electrical panel and to the ground lug of the pool heat pump. An improper installation may be a potential cause of fire, electrical shock or injury.

Bonding

⚠ VITAL

In some locations bonding of the pool equipment and pool substructure may be required by law. Because all metals have different electrical potentials, **ALL metal and electrical components of the pool system MUST be bonded together.** This includes the metal framework of the pool, the light, the pump, the filter (if metal), the pool heat pump, any automatic chlorine generator, and any other metal or electrical equipment bonded to your pool.

On some older pools, this substructure bond wire may not exist. In these cases, a 3-4 foot solid copper rod must be driven into the ground near equipment; all electric and metal components must be bonded to each other, and to the copper rod. Warranty will be voided if system is not properly bonded.

CAUTION: Some of these systems may leak stray voltage and currents into the water causing severe electrolysis. This dramatically shortens the life of the pool heat pump and will void the warranty.

When an automatic chlorinator is installed on a pool circulation system, it is important the equipment is correctly installed and bonded (earthed). Some systems may leak stray voltage and currents into the water causing severe electrolysis which could shorten the life of the pool heat pump.

NOTE: Bonding to pool pump is not required to above ground pool pumps but all other equipment must be bonded.

Bonding Diagram

⚠ VITAL

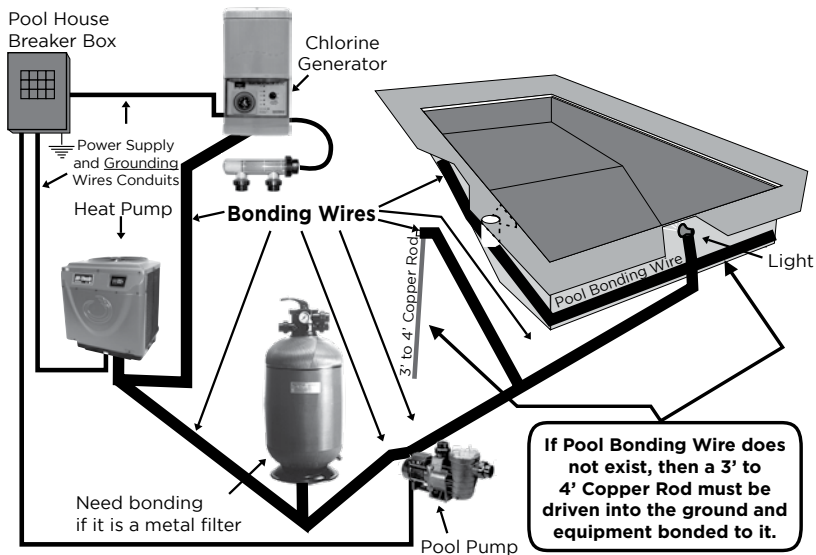

Remote Control Connections

1. Switch off power to heat pump at main circuit breaker panel/isolator.
2. Unbolt and remove the front access panel.
3. Open control box cover.
4. To connect a 2-Wire Control such as Waterco Aquamaster™:
 - ii) Locate the main printed circuit board and cable connected to terminal IN4 WP (Water Flow Switch).
 - ii) Cut the loop cable in terminal IN4 and connect the two ends of the cut cable separately to the two ends of the incoming external controller cable and make electrically safe. Use 1mm² minimum cable size with a minimum 1.2mm thick insulation rated for a temperature of at least 105°C / 221°F.
5. Close control box cover.
6. Re-install the access panel. To control heaters that are operated in parallel, connect wiring at same locations on heater control. It is imperative that each control circuit is isolated from the other control circuits; to avoid current flow from one heater to another through the control circuits.

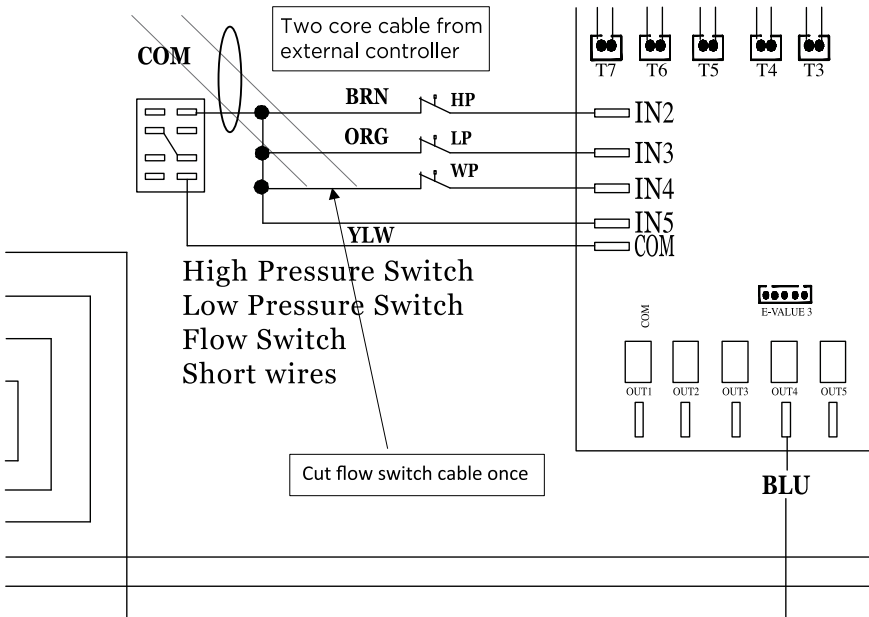

Usage Of Chemical Products

When adding chemicals to your pool or spa, follow the manufacturers guidelines for application and dosing levels.

Allowing high concentrations of chemicals through the heater should be avoided. Resultant damage may be inflicted on the heater.

Water quality standards that must be strictly adhered to*:

DESCRIPTION	NORMAL RANGE*	VERIFY
PH Level	7.2 - 7.6	1 per week
Chlorine Concentration	2 - 5 PPM	1 per 2-3 days
Total Alkalinity	80 - 150 PPM	1 per 2-3 weeks
Total Dissolved Solids	Below 1500 PPM Reg Pool Below 7500PPM Salt Pool	1 per month 1 per month
Calcium Hardness	200 - 300 PPM	1 per month
Salt Level	4000 - 6000 PPM	

* Warranty can be voided if not maintained within these ranges.

Refrigerant Charge Indicator Gauge

The refrigerant charge gauge is provided to monitor the refrigerant charge within the heat pump. When the heat pump is operating, the gauge needle would point to the pressure value of refrigerant with the maximum value of protection of 42kg/Cm². When the heat pump is off, the gauge needle would point to the same value as actual ambient temperature (e.g. 28°C) and related air pressure (e.g. 18kg/Cm²).

If the needle is pointing in the range of 0 - 3 then it may indicate low refrigerant charge and should be checked by a qualified technician.

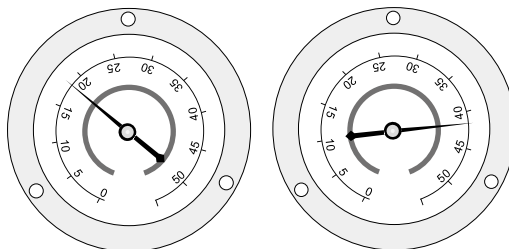

Performance Specifications

°C			Electroheat ECO V 39KW	Electroheat ECO V 38KW	Electroheat ECO V 48KW
Air 27°C/ Water 26°C	Heating Capacity	KW	39.0 - 15.2	37.6 - 14.3	47.6 - 18.5
	Power Input	KW	7.5 - 1.8	7.2 - 1.75	8.7 - 2.2
	Normal Current	A	34 - 8.1	12.0 - 2.93	14.6 - 3.7
	COP		5.2 - 8.4	5.2 - 8.2	5.4 - 8.4
Air 15°C/ Water 26°C	Heating Capacity	KW	32.1 - 12.0	31.5 - 12.0	41.5 - 16.1
	Power Input	KW	7.21 - 1.79	7.33 - 1.79	9.88 - 2.48
	Normal Current	A	32.3 - 8.02	12.1 - 2.96	16.3 - 4.10
	COP		4.45 - 6.7	4.30 - 6.7	4.2 - 6.5
Power Supply		V/Ph/Hz	230V/1Ph/50Hz	380 - 415V/3Ph/50Hz	
Setting Temp. Range		°C	15°C - 40°C		
Running Temp. Range		°C	-10°C - 43°C		
Water Heat Exchanger			Titanium Coil / PVC Tank		
Heat Exchanger Max. Pressure			3.5 bar / 350kPa		
Compressor			Inverter		
Compressor Quantity			1		
Fan quantity			2		
Exhaust Direction			Vertical		
Water Inlet/Outlet Dimension			2"		
Hydraulic Connection		MM	50 SLIP		
Nominal Water Flow		LPM	200 - 230	250 - 270	
Sound Pressure Level at 1M		dB(A)	50 - 59		
Sound Pressure Level at 10M		dB(A)	32 - 42		
Unit Dimentions(L*W*H)		MM	1450*702*950		1450*702*1260
Net Weight		Kg	180		236
Evaporator Area		m ²	3.75	3.75	5.00
Refrigerant			R32		
Display			LCD		
Mode			Heating/Cooling		

OPERATION OF YOUR POOL HEAT PUMP

Initial Heating

To achieve initial heating, your pool heat pump and the pool pump may require extended operation until desired temperature is achieved. The initial heating time may vary depending upon the five factors listed below. After initial heating, operating time may be reduced to match daily heat loss.

1. Size of the pool.
2. How many degrees the water is to be heated.
3. Ambient air temperature - the warmer the air, the less time required to heat.
4. Use of a solar blanket.
5. The size of the pool heat pump.

If a combination of the atmospheric and water temperatures are below the minimum listed concurrently the pool heat pump should not be operated and be switched off.

Generally, atmospheric conditions (air temperature) will be warmer during day time hours. To accelerate the initial heating period owners may opt to increase the ambient air temperature artificially around the evaporator area of the pool heat pump until the pool water temperature has reached the minimum required as stated below.

Model	Atmospheric conditions must be above	Pool water temperature must be above
Electroheat ECO-V	0°C / 32°F	10°C / 50°F

Adjustment Of The Bypass Valves

Waterco ECO-V pool heat pumps do not require the water by pass valves adjusted to cope with cooler water temperatures. In the event of low water temperatures, the ECO - V inverter pool heat pumps increase the operating frequency of the compressor which in turn increases the output capacity of the unit.

It is essential water flow through the unit is within the range specified in the Performance Specifications table in this manual. The bypass valve may be used to tune the water flow within range to achieve a 2-3 degree C temperature rise between the cold water inlet and warm water outlet at 27 degrees Celsius ambient air temperature.

The adjustment may vary according to pool pump size.

Pool Heat Pump Running Time

Most units should be sized to operate during the pool filtering cycle time of 8-12 daytime hours daily during warmer months and up to 8 hours daily during the daytime in winter months. On warmer days the pool heat pump will run less because the heat loss will be less.

IMPORTANT

Condensation

Your pool heat pump will accumulate condensed water (approx. 4 to 6 litres or 1 to 1.5 gallons per hour), therefore causing water to drain out of the unit base. In order to avoid water accumulation, you may use decorative rocks around the concrete slab or a basin under the unit. *(Please note this is a normal characteristic of a pool heat pump and not a service or warranty issue.)*

A hose may be connected to the spigots fitted prior to final unit installation to direct the condensate away from the heat pump.

Pool Solar Blanket

A pool solar blanket should be used whenever possible. Blankets minimize heat loss through evaporation and conserve heat in your pool. Un-blanketed pool can lose 2-3 times more heat than a blanketed pool.

Defrost Cycle

When any of the following conditions occur the electronic control of your unit will activate a defrost mode until most of the frost from the evaporator has melted. Condensation of water on the evaporator coil tends to frost up quicker when the following occur.

1. When atmospheric conditions are as stated above;
2. When the evaporator is dirty;
3. When installation clearances are not respected.







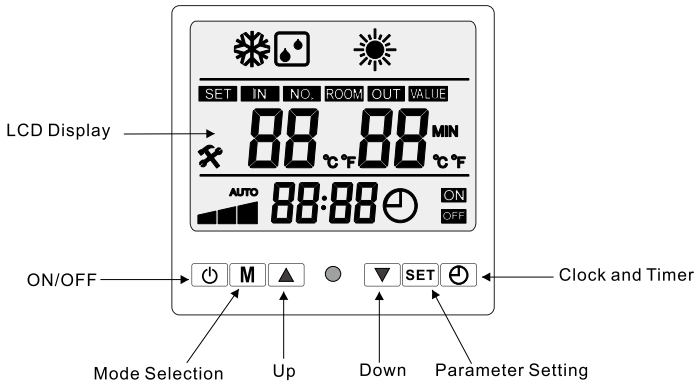



Defrost is activated for between 3 to 20 minutes.

INVERTER POOL HEAT PUMP CONTROLLER

This controller applies to DC inverter air source pool heat pumps, for heating.



Button Operation:

1. On/Off: Press the “” button on the main interface to switch between the On/Off status;
2. Mode switching: Press the “M” button on the main interface to switch between the operation modes;
3. Button locking: Press and hold the “▲” and “▼” buttons for 5S at the same time on the main interface to lock the buttons, and the icon  will appear on the screen when the buttons are locked. Repeat the operation to unlock;
4. Manual defrosting: Press the “” and “” buttons for 5s at the same time in the power-on state to start forced defrosting;
5. Parameter resetting: Press the “”, “M” and “” buttons for 5 seconds at the same time to reset the parameters
6. Clock setting: Press the “” button on the main interface to enter the clock setting interface. After entering the clock setting screen, the hour flashes first, and you can use the “▲” or “▼” to adjust the hour. After the hour is set, press the “” button to enter the minute setting. After the minute is set, press the “” button to complete the clock setting and return to the main interface.
7. Timing setting: Press the “” button on the main interface to enter the timing setting interface. After entering the timing setting interface, the hour in the time period 1 setting starts flashing, and you can use the “▲” or “▼” to adjust the hour. In the adjustment process;



press the “” button to switch to the next time period setting until the timing setting of the two time periods is completed. Press the “” button during any time period setting to cancel the time period.
8. Other operations: Press and hold the “” button for 5s to enter the password setting interface, enter “8563” to enter the time limit setting interface, enter “9615” to enter the manual frequency status, and enter “8866” to switch between the display frequency (clock display window).

Illustration for LCD Display



Normal display in heating mode

ON/OFF

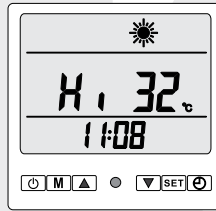
When you switch OFF the machine on the controller, the display will indicate «Standby»

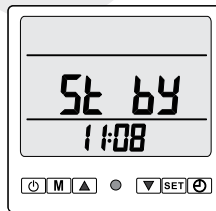







Button  serves to start/stop the heat pump.

After stopping the machine with this button, it can take a few minutes till the machine comes to a complete hold.

Working modes

Button  serves to change the working mode.

By pressing this button, the icon corresponding to the selected mode will appear:

-  +Lo "Eco" Heating mode: the machine manage its power and keep low noise / low speed
Heats the water up to the desired value (+/- 1°C)*
-  +NE "Smart" Heating mode: machine manage it's power for best efficiency.
Heats the water up to the desired value (+/- 1°C)*
-  +H "Boost" Heating mode: the machine manage its power and keep high power.
Heats the water up to the desired value (+/- 1°C)*
-  +Lo "Eco" Cooling mode: the machine manage its power and keep low noise / low speed
Heats the water up to the desired value (+/- 1°C)*
-  +NE "Smart" Cooling mode: machine manage it's power for best efficiency.
Heats the water up to the desired value (+/- 1°C)*
-  +H "Boost" Cooling mode: the machine manage its power and keep high power.
Cools the water down to the desired value (+/- 1°C)*

Time Setting

- Press **SET** key (hours will blink)
- Set hours with **▲** or **▼**.
- Press one time button **SET** (minutes will blink)
- Set minutes with **▲** or **▼**.
- Press one time button **SET** to confirm.

Water temperature setting

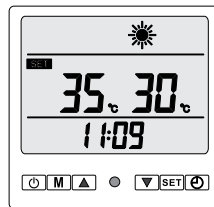

Start the machine and choose the desired mode (see precedent instructions).

When pressing this button **▲** the display will indicate "SET" and the desired water temperature.





Adjust the desired value with **▲** or **▼** and wait a few seconds till it is stored automatically.

Water information

- Symbol  indicates that the machine is defrosting.
- Symbol  indicates that the keyboard is locked.
To lock or unlock the keyboard press **▲** and **▼** simultaneously during several seconds.

Operation Modes

-  Cooling mode symbol
-  Defrosting symbol
-  Heating mode symbol

Memory Function

The heat pump controller should memorise ON / OFF status, operating mode, parameter and timer settings. When power is connected and the heat pump is switched on, the unit will start operation based on the settings when power was switched off previously.

MAINTENANCE OF YOUR POOL HEAT PUMP

Waterco pool heat pumps have been specifically engineered to give you years of satisfaction and enjoyment in the pool.

Cabinet Cleaning

To clean the plastic and painted surfaces use mild soapy water and a soft clean cloth. Never use solvents or abrasives.

Cleaning Evaporator

The evaporator at the rear of the unit must be kept clean and un-obstructed in order for your pool heat pump to have better efficiency and avoid problems which may void your warranty. The dirt collected in the evaporator can be removed with a gentle water spray and the use of a soft brush. Be careful not to damage the aluminum fins.

Cleaning drainage holes

The condensate drainage holes in the base of the unit must be kept free of debris. Blocked drainage holes may cause water to collect in the unit and become stagnant or, interfere with electrical components and wiring.

Issues caused by blocked drainage holes in the base of the unit are not covered under warranty.

Units Located In Coastal Locations

Care and maintenance procedures for Waterco Pool Heat Pumps installed in coastal locations.

Exposure to salt may result in evaporator coil damage shortening the life of the equipment.

Electroheat ECO-V pool heat pumps are fitted with evaporators treated with hydrophilic blue fin technology. The advantages are:

The epoxy coating on the coils prevents accumulation of salt, acid, dust and water deposits which minimises the effects of corrosion.

Hydrophilic blue fin condensers do not allow water droplets to accumulate which can increase the efficiency of the pool heat pump.

Pool heat pumps located within 1 kilometre from the coast should be given a monthly rinse with potable water straight from the garden hose connected to the municipal water system to remove the salt build up on the evaporator coil and exposed metal surfaces.

Consult your installer for third party anti corrosion treatments.

Winterising Procedure

VITAL

If the pool heat pump is stored in a place where the temperature drops below the freezing point of 0°C / 32°F; it is **mandatory that the water accumulated in the pool heat pump be drained completely before freezing weather prevails. Improper winterizing may damage the pool heat pump and will void the warranty.**

- Turn the pool heat pump “**OFF**”.
- Turn the pool heat pump breaker “**OFF**”.
- The water piping **MUST** be disconnected to drain the pool heat pump’s heat exchanger in preparation for winter.
- Once the piping is disconnected, the pool heat pump’s heat exchanger **MUST** be emptied; the use of a water vacuum cleaner is strongly recommended or if you do not have this tool you may tilt the unit (75°) until all the water is out.
- It is recommended that pool heat pump’s heat exchanger is rinsed out with a gentle water spray at the inlet and outlet water connections of the pool heat pump and then drain the heat exchanger again.
- With the help of 2 pool return winter plugs, block the water Inlet and Outlet connections to prevent access by vermin.
- Clean the drainage holes located at the bottom of the base of the unit.
- Unit may be covered for the winter.
- It is also possible to fill the heat exchanger with pool anti-freeze, but ensure that the antifreeze contains an elevated pH to prevent corrosion. This is optional and requires appropriate hardware.

GENERAL SAFETY INSTRUCTIONS

DO NOT DEPRIVE YOUR POOL HEAT PUMP OF WATER FLOW FOR MORE THAN 24 HOURS WITHOUT DRAINING IT. Make sure you leave the bypass valves as shown in Figure 1.

At the end of each season, when the pool heat pump is no longer in use, and proper pool water chemistry is not maintained, it should be disconnected from the water line and drained to prevent any possible corrosion or damage to the pool heat pump. Refer to Figure 1 below or winterising procedure (page 24).

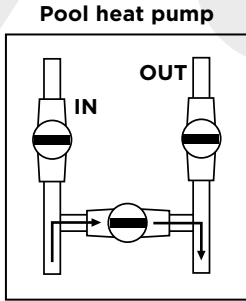

When your valves position are as shown on Figure 1, the water is bypassing the pool heat pump.

Figure 1

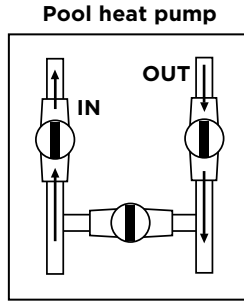

When your valves position are as shown on Figure 2, the water is going through the pool heat pump.

Figure 2

The valves shown above may be different to the ones installed on your system. Please ensure you understand how your bypass valve operates.

TROUBLESHOOTING

Please ensure the unit and any related equipment is installed in accordance with the installation manual. If not, the Waterco warranty will not apply and the customer may be liable for service call charges.

Nothing Is Working And The Electronic Control Does Not Operate

1. Ensure the circuit-breaker has not tripped and/or the fuses have not blown;
****Take note that only an electrician can verify if the circuit breaker is defective; if this is the case, repairs will not be covered under the warranty.**
2. For three phase models, this situation could occur when phases are not in the appropriate order.

Please have a qualified electrician swap over two of the incoming phase wires.

Nothing Is Working But The Electronic Control Temperature Displays Digits Or A Code

1. Identify the analyser code that the electronic control displays and refer to the Service Analyser codes section;
2. If the electronic control displays digits, make sure that the electronic control is programmed correctly, refer to the Operation of your pool heat pump and reprogram if necessary.

***Note that this situation could occur when the electrical voltage is not respected as stated on the pool heat pump name plate. This situation is not covered by the manufacturer warranty.*

Fan Doesn't Work (the fan blades are not moving)

1. IMPORTANT: For safety, switch OFF the circuit-breaker.
2. Try to rotate the fan blades of the fan with a rod to see if the motor is jammed or seized
3. If the fan blades do not turn freely leave the unit switched OFF and call for service;
4. If the fan blades turn freely switch ON the circuit breaker and the pool heat pump again.

*** Note that your fan motor may have an electrical fault if the blades turn freely when the unit is switched OFF and does not start when the unit is switched ON.*

Fan Blades Turn, But Compressor Is Not Functioning

The pool heat pump has a built in delay timer which prevents the compressor from starting immediately. The delay can be 3 to 5 minutes in duration after the fan blades have turned. Furthermore if the unit is in defrost mode the compressor will not start for 3 to 20 minutes.

1. Check that air being discharged from the fan blades is colder than the ambient air. If the air being discharged by the fan blades is colder, it means that the compressor is functioning correctly.
2. Turn off the pool heat pump then immediately turn it back on;
3. As soon as the fan blades start turning, wait a minimum of 3-5 minutes. The compressor should start up after this time and you will be able to identify a different sound made by the compressor when it starts;
4. If the compressor is functioning, but shuts off immediately, consult the following section "Compressor Starts and Stops".
5. If the problem persists, call your local Waterco office for assistance.

Compressor Starts And Stops

1. Check that the unit has been installed correctly (refer to installation procedures).
2. Check that the water inlet and outlet of the unit have not been connected incorrectly.

There Is Water Around The Pool Heat Pump

It is a normal occurrence for water condensation, to be seen running from the unit base. There will be on average 1 to 1.5 gallons (4 to 6 litres) of condensed water per hour being discharged from the unit base. In order to avoid water accumulation, you may use decorative rocks around the concrete slab or a basin under the unit. Be sure that clearances around the unit are respected.

To test the unit and confirm you have no pool water leaking from the unit perform the following test which is best performed early in the morning and continuing for the whole day:

1. Turn off the pool heat pump from the circuit breaker and the pool pump.
2. Open the bypass valve. (refer to drawing on page 5)
3. Close the **IN** and **OUT** water valves on the unit.
4. Restart the pool pump. The pool heat pump must remain **OFF**.
5. When all of the water around the base of the pool heat pump has dried, open the water **IN** and water **OUT** valves on the pool heat pump.
6. Close the bypass valve to allow full water flow through the pool heat pump.

If water is now seen running from the outside of the pool heat pump or inside the pool heat pump after a short period of time you should call for service. If no water is seen after a short period of time it would be assumed the water was condensation which is normal.

Pool Heat Pump Has Ice Formed On The Evaporator Coil

1. **IMPORTANT:** For safety, switch OFF the circuit-breaker.
2. Allow the ice to melt and then inspect the evaporator to ensure it is free of debris and leaves.
3. If the evaporator is dusty or dirty, clean it with a light spray of water and allow it to dry (do not use high pressure it may damage the evaporator fins).
4. When the unit is dry, you may switch it back ON from the circuit breaker.
5. Ensure that the clearances around the unit are respected.
6. When the unit has been switched ON ensure the fan motor is working (fan blades will be turning) while the compressor is operating.
7. If the fan blade does not turn and the compressor is functioning; notify customer service.

***If the pool heat pump requires service, the owner of the pool heat pump will need to ensure the unit has been switched OFF to allow any ice to melt prior to any technician attending.*

Pool Heat Pump Is Functioning, But Does Not Reach The Desired Temperature Setting

IMPORTANT

Improper installation may cause this situation and will need to be corrected by the owner.

1. Ensure the by-pass valves are in the correct positions to ensure sufficient water flow, insufficient water flow will cause the compressor to shut off early.
2. If you have installed a timer or the pool heat pump is equipped with an integrated timer, be sure it is programmed to allow the pool pump to work for sufficient time in order to reach the programmed temperature.
3. Ensure the evaporator is cleaned regularly with a light spray of water and allowed to dry before re-starting the pool heat pump to avoid premature ice build up on the evaporator.
4. Waterco recommend the use of a solar cover to retain heat in pool water. Pools without covers lose 2 to 3 times more heat than pools with solar covers.
5. Make sure the electronic control of your pool heat pump has been programmed correctly; during this test the pool heat pump and water pump must be working continuously (eg; the desired water temperature must be set correctly).
6. If the unit continually fails to reach the desired water temperature, we suggest completing the following analysis chart and forwarding it to Waterco in order to avoid unnecessary service fees.

Circuit Breaker Trips

IMPORTANT

If you have purchased a remote control (or other equipment), ensure the equipment is correctly installed. If an operational issue originates from incorrect operation or installation of this equipment, Waterco's warranty will not apply and you will have to pay the cost of the service call.

1. The amperage of the circuit breaker AND the electrical wiring must be as the instructions on the pool heat pump name plate, otherwise notify your installer or electrician to correct this problem, as this is not covered under the warranty.
2. If the circuit breaker and electrical wiring are as stated, make sure the drains, located on each side of the base of the pool heat pump are not obstructed.

The Pool Heat Pump Is Noisy

1. Check the pool heat pump is level and on a solid base to prevent any vibrations issues.
2. Ensure the noise is coming from the pool heat pump, not from other equipment which will not be covered by the warranty (for example: noise coming from the bypass valve, pool pump, etc);
3. An improper installation may cause this situation it will need to be corrected by the owner.

The Temperature Shown On Pool Heat Pump Is Not The Same That Is Shown By The Pool Thermometer

It is possible to have a temperature variation between the temperature shown on the electronic control temperature display of the pool heat pump and a pool thermometer which may be read from different locations.

- Check that there are no leaks on the pool plumbing (there should be no air leaks in the pipework);

Dimensional drawing of heat pump

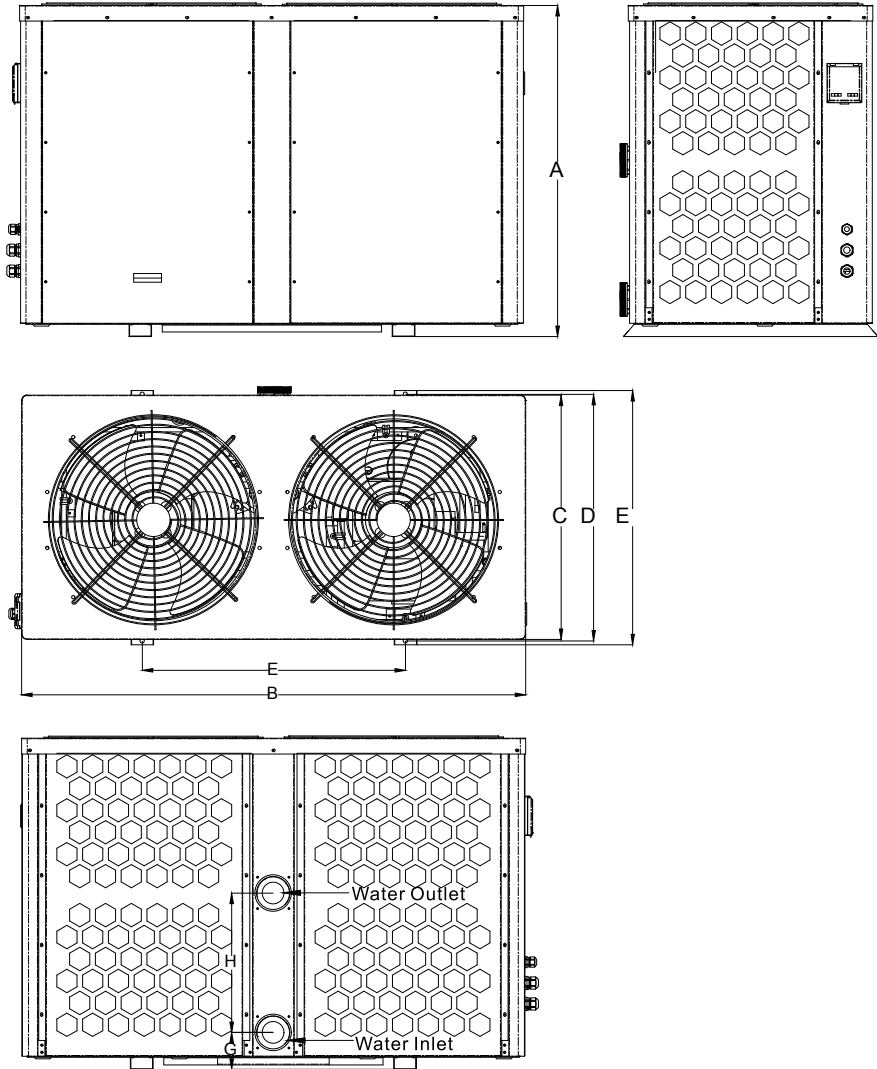

	A	B	C	D	E	G	H
Electroheat ECO V 38 / 39KW	950	1450	702	708	730	106	400
Electroheat ECO V 48KW	1260	1450	702	708	730	106	450

Electric Circuit Drawing

Electroheat ECO-V 39kW

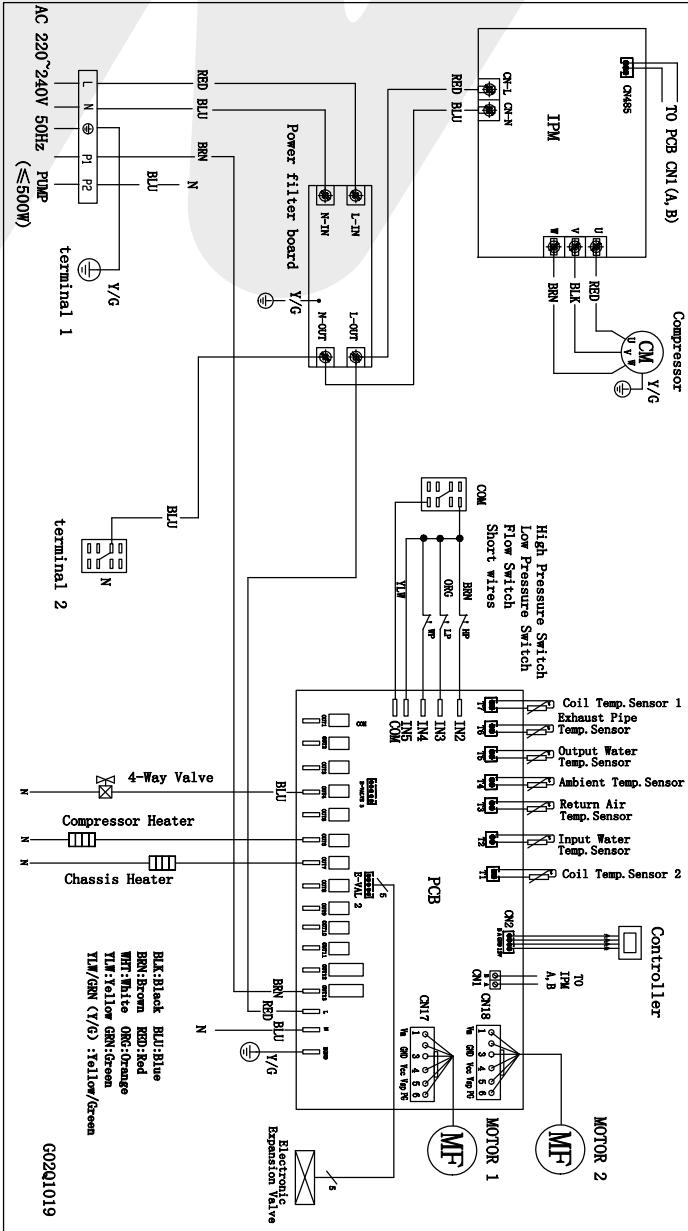

Electroheat ECO-V 38 & 48kW

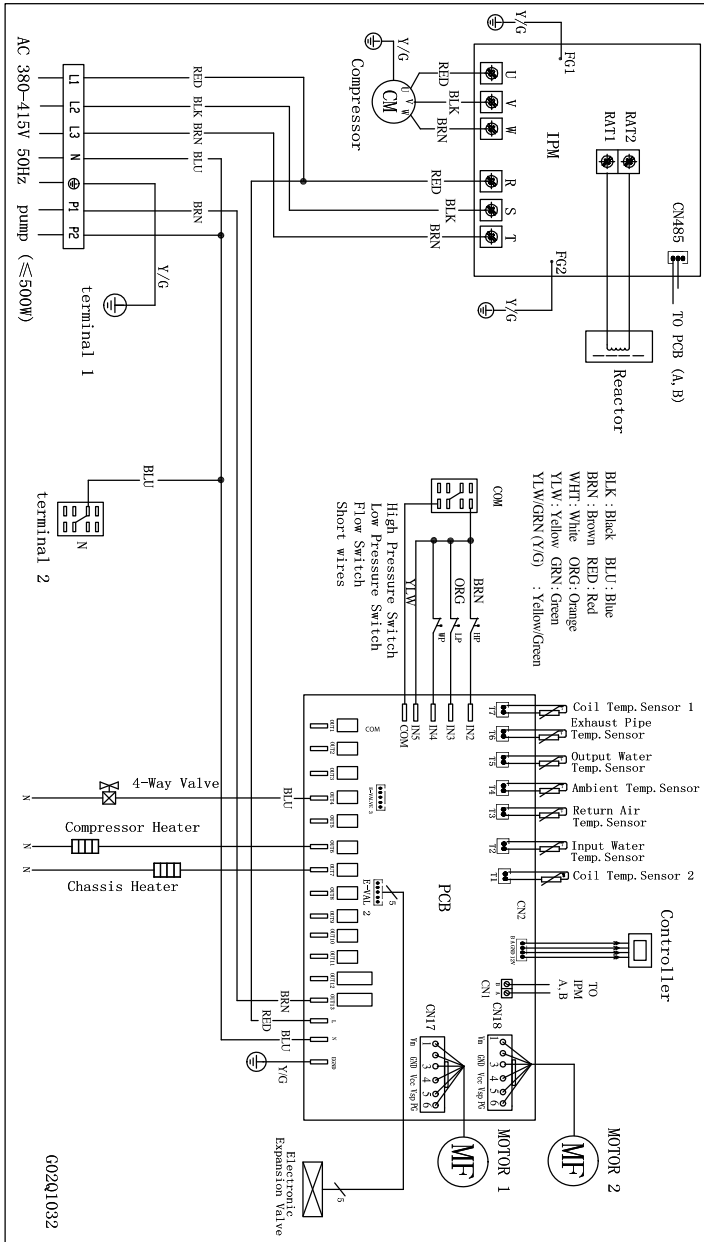

G02Q1032

Service Parameters Tables

Press and hold the “” button for 5s to enter the status query:

Query Code	Meaning	Display Range
01	Inlet water temperature	-20-99°C
02	Outlet water temperature	-20-99°C
03	Ambient temperature	-20-99°C
04	Exhaust temperature	0-125°C
05	Return air temperature	-20-99°C
06	Outer coil temperature	-20-99°C
07	Inner coil temperature	-20-99°C
08	Main expansion valve opening	Actual value/10
09	Enthalpy increase expansion valve opening	Actual value/10
10	Press current	
11	Heat sink temperature	
12	DC bus voltage	Actual value/10
13	Compressor press actual frequency	
14	DC fan voltage	

Error code table

Code	Description	Remark
Er02	DC fan 1 failure	
Er03	Flow side error	
Er04	Freeze in piping in winter	
Er05	High pressure switch error	
Er06	Low pressure switch error	
Er09	Communication failure	
Er10	PCB error	
Er11	Reserve	
Er12	High discharge temp error	
Er15	Water inlet probe error	
Er16	Defrost probe error	
Er18	Discharge probe error	
Er20	PCB abnormal error	
Er21	Ambient probe error	
Er23	Lower water outlet temp error in cooling mode	
Er27	Water outlet probe error	
Er29	Suction temp error	
Er32	Higher water outlet temp error in heating mode	
Er33	High temperature protection of evaporator coil	
Er42	Tube temperature fault of titanium heat exchange	
Er46	DC fan 2 failure	

Parameter Number and Description Table

Press and hold the “Set” key for 5s to enter the password setting interface; enter “0814” to enter the parameter query interface:

Setting Code	Parameter Name	Adjustment Range	Initial Value
01	Air conditioning temperature difference	1°C ~ 18°C	1°C
02			
03			
04	Cooling temperature setting	7°C ~ 30°C	12°C
05	Heating temperature setting	15°C ~ 50°C	35°C
06	Temperature setting for protection against excessive exhaust temperature	80°C ~ 125°C	120°C
07	Recovery temperature setting for excessive exhaust temperature	50°C ~ 100°C	95°C
08	Press current protection	2A ~ 50A	20A
09	Inlet water temperature compensation	-5°C ~ 15°C	0°C
10	Reserved		
11	Defrosting cycle	20MIN ~ 90MIN	45MIN
12	Defrosting entry temperature	-15°C ~ -1°C	-3°C
13	Defrosting time	5MIN ~ 20MIN	10MIN
14	Defrosting exit temperature	1°C ~ 40°C	20°C
15	Defrosting environment and coil temperature difference	0°C ~ 15°C	5°C
16	Defrosting ambient temperature	0°C ~ 20°C	17°C
17	Main expansion valve operating cycle	20S ~ 90S	30S
18	Overheat for heating target	-5°C ~ 10°C	1°C
19	Exhaust temperature for main expansion valve regulation	70°C ~ 125°C	95°C
20	Defrosting expansion valve opening	20 ~ 450	400
21	Main expansion valve minimum opening	50 ~ 150	80
22	Main expansion valve mode selection	0-manual/ 1-automatic	1
23	Main expansion valve manual levels	20 ~ 450	350
24	Overheat for cooling target	-5°C ~ 10°C	0°C
25	Enthalpy increase expansion valve manual levels	20 ~ 450	350
26	Ambient temperature for enthalpy increase starting	11°C ~ 45°C	23°C

Setting Code	Parameter Name	Adjustment Range	Initial Value
27	Cooling main valve mode	0-ambient/ 1-overheat	1
28	Constant temperature pump mode	1-normally open/ 0-closed	1
29	F1	15 ~ 120Hz	45 Hz
30	F2	15 ~ 120Hz	50 Hz
31	F3	15 ~ 120Hz	55 Hz
32	F4	15 ~ 120Hz	60 Hz
33	F5	15 ~ 120Hz	65 Hz
34	F6	15 ~ 120Hz	70 Hz
35	F7	15 ~ 120Hz	75 Hz
36	F8	15 ~ 120Hz	80 Hz
37	F9	15 ~ 120Hz	85 Hz
38	F10	15 ~ 120Hz	91 Hz
39	Exhaust setting TP0	50 ~ 125°C	95°C
40	Exhaust setting TP1	50 ~ 125°C	100°C
41	Exhaust setting TP2	50 ~ 125°C	105°C
42	Exhaust setting TP3	50 ~ 125°C	110°C
43	Exhaust setting TP4	50 ~ 125°C	120°C
44	Exhaust limit main expansion valve down 1	50 ~ 125°C	61°C
45	Exhaust limit main expansion valve down 2	50 ~ 125°C	65°C
46	Exhaust limit main expansion valve down 3	50 ~ 125°C	70°C
47	DC fan gear 1	10 ~ 100	40
48	DC fan gear 2	10 ~ 100	50
49	DC fan gear 3	10 ~ 100	60
50	DC fan gear 4	10 ~ 100	70
51	DC fan gear 5	10 ~ 100	85
52	DC fan gear 6	10 ~ 100	90
53	DC fan gear selection	1 ~ 6	2

WARRANTY

Waterco's obligation to repair or replace at Waterco's option, shall be the original purchaser's sole and exclusive remedy under this warranty. Waterco shall not be liable for incidental, consequential or special damages arising out of or in connection with product use or performance.

Waterco is not responsible for direct or indirect damages resulting from defective components. This warranty gives you specific legal rights and you may also have other rights, which vary from state, province or country to another.

Prior to contacting Waterco for assistance or service, please check the "Troubleshooting" and the information stated in this section. Warranty will only cover manufacturing defects. All service call requests which are not of this nature must be paid by the purchaser to the service company authorized by Waterco.

All services will be handled by the authorized service company. Warranty may be voided if service is not carried out by a Waterco authorised service agent.

DO NOT return the pool heat pump to your dealer as they do not provide the service work.

Prior to contacting Waterco for assistance Waterco for assistance or service, in order to qualify for a warranty claim, the original purchaser must have the model name and serial number along with a proof of the original purchase date. Proof of purchase must be forwarded to Waterco and they will inform you of the applicable warranty.

Once connected with a Waterco customer service agent, proceed to describe in detail the issue associated with your pool heat pump. If a permanent code appears on the electronic control panel, please advise the Waterco service agent.

There are no other warranties, express or implied, including, but not limited to, implied warranties of merchantability or fitness for a particular purpose. During warranty period, Waterco will, at its option, repair or replace, without charge, any product or part, which is found to be defective under normal use and service.

IMPORTANT : The warranty is not transferable and no action can be exercised by a consumer subsequent purchaser of the pool heat pump.

Waterco does not guarantee and will not pay for:

A. Service calls to:

1. Inspect and/or correct the installation of your pool heat pump.
2. Instruct you on how to use your pool heat pump.
3. Replace house fuses or correct power supply problem.
4. Adjust or reestablish water flow to the pool heat pump.

B. When a service call with no manufacturing problem has been detected, on site, by the service company mandated by Waterco.

This Warranty does not cover:

A. Damage, issues or unsatisfactory performance caused to the equipment by faulty or incorrect external electrical wiring, incorrect power supply, voltage fluctuations, over voltage transients or electromagnetic interference not originating within the equipment.

Visit www.waterco.com.au/customer-service/warranty-terms for our full Warranty Terms and Conditions.

NOTE

OFFICES - AUSTRALIA

NSW - SYDNEY
(HEAD OFFICE)
Tel : +61 2 9898 8686

VIC/TAS - MELBOURNE
Tel : +61 3 9764 1211

WA - PERTH
Tel : +61 8 9273 1900

QLD - BRISBANE
Tel : +61 7 3299 9900

SA/NT - ADELAIDE
Tel : +61 8 8244 6000

ACT DISTRIBUTOR
Tel : +61 2 6280 6476

OFFICES - OVERSEAS

WATERCO (EUROPE) LIMITED
Sittingbourne, Kent, UK
Tel : +44 (0) 1795 521 733

WATERCO USA
Augusta, USA
Tel : +1 706 793 7291

WATERCO CANADA
Boucherville, Quebec, Canada
Tel : +1 450 748 1421

WATERCO (NZ) LIMITED
Auckland, New Zealand
Tel : +64 9 525 7570

WATERCO (C) LIMITED
Guangzhou, China
Tel : +8620 3222 2180

WATERCO (FAR EAST) SDN BHD
Selangor, Malaysia
Tel : +60 3 6145 6000

PT WATERCO INDONESIA
Jakarta, Indonesia
Tel : +62 21 4585 1481

WATERCO SINGAPORE INTL PTE LTD
MAPEX Building, Singapore
Tel : +65 6344 2378

WATERCO VIETNAM COMPANY
LIMITED
Ho Chi Minh City, Vietnam
TEL: +84 28 3622 7780

www.waterco.com.au

This web site address will enable you to select the appropriate country website.

WATERCO

Waterco Limited ABN 62 002 070 733

